



NAVAL POSTGRADUATE SCHOOL

Monterey, California



THESIS

K8624

THE USE OF SEAPLANES AS AN
ADVANCED WEAPON SYSTEM

by

Algeu Kreniski

September 1988

Thesis Advisor:

M. F. Platzer

Approved for public release; distribution is unlimited

T242021

REPORT DOCUMENTATION PAGE

REPORT SECURITY CLASSIFICATION UNCLASSIFIED		1b RESTRICTIVE MARKINGS	
SECURITY CLASSIFICATION AUTHORITY		3 DISTRIBUTION/AVAILABILITY OF REPORT Approved for public release; distribution is unlimited	
DECLASSIFICATION/DOWNGRADING SCHEDULE		5 MONITORING ORGANIZATION REPORT NUMBER(S)	
PERFORMING ORGANIZATION REPORT NUMBER(S)		7a. NAME OF MONITORING ORGANIZATION Naval Postgraduate School	
NAME OF PERFORMING ORGANIZATION Naval Postgraduate School	6b OFFICE SYMBOL (If applicable) Code 67	7b. ADDRESS (City, State, and ZIP Code) Monterey, California 93943-5000	
ADDRESS (City, State, and ZIP Code) Monterey, California 93943-5000		9 PROCUREMENT INSTRUMENT IDENTIFICATION NUMBER	
NAME OF FUNDING SPONSORING ORGANIZATION	8b OFFICE SYMBOL (If applicable)	10 SOURCE OF FUNDING NUMBERS	
ADDRESS (City, State, and ZIP Code)		PROGRAM ELEMENT NO.	PROJECT NO.
		TASK NO.	WORK UNIT ACCESSION NO.
TITLE (Include Security Classification) The Use of Seaplanes as an Advanced Weapon System			
1 PERSONAL AUTHOR(S) Kreniski, Algeu			
1a. TYPE OF REPORT Master's Thesis	13b TIME COVERED FROM _____ TO _____	14. DATE OF REPORT (Year, Month, Day) 1988, September	15 PAGE COUNT 110
5 SUPPLEMENTARY NOTATION The views expressed in this thesis are those of the author and do not reflect the official policy or position of the Department of Defense or the U.S. Government.			
7 COSATI CODES		18 SUBJECT TERMS (Continue on reverse if necessary and identify by block number)	
FIELD	GROUP	Seaplane Technology, Weapon Systems Studies, Aeronautical Engineering	
9 ABSTRACT (Continue on reverse if necessary and identify by block number)			
<p>In this thesis the military potential of giant seaplanes as carriers of fighter/attack aircraft is considered. After a survey of past seaplane developments possible scenarios to demonstrate the utility of seaplane carriers are discussed. This is followed by preliminary seaplane sizing, design, and operational considerations. It is concluded that a fleet of Boeing 747-size amphibian planes carrying one or two F-5-size fighter/attack planes offers new and attractive military possibilities that merit further evaluation.</p>			
10 DISTRIBUTION/AVAILABILITY OF ABSTRACT <input checked="" type="checkbox"/> UNCLASSIFIED/UNLIMITED <input type="checkbox"/> SAME AS RPT. <input type="checkbox"/> DTIC USERS		21. ABSTRACT SECURITY CLASSIFICATION Unclassified	
2a NAME OF RESPONSIBLE INDIVIDUAL Prof. M. F. Platzer		22b TELEPHONE (Include Area Code) (408) 646-2058	22c OFFICE SYMBOL Code 67P1

Approved for public release; distribution is unlimited.

THE USE OF SEAPLANES AS AN
ADVANCED WEAPON SYSTEM

by

Algeu Kreniski
LTCol, Brazilian Air Force
B.S., Fund. Tecnico Educ. Souza Marques, Brazil, 1974

Submitted in partial fulfillment of the
requirements for the degree of

MASTER OF SCIENCE IN ENGINEERING SCIENCE

from the

NAVAL POSTGRADUATE SCHOOL
September 1988

//

ABSTRACT

In this thesis the military potential of giant seaplanes as carriers of fighter/attack aircraft is considered. After a survey of past seaplane developments possible scenarios to demonstrate the utility of seaplane carriers are discussed. This is followed by preliminary seaplane sizing, design, and operational considerations. It is concluded that a fleet of Boeing 747-size amphibian planes carrying one or two F-5-size fighter/attack planes offers new and attractive military possibilities that merit further evaluation.

TABLE OF CONTENTS

I. INTRODUCTION.....1

II. THE SEAPLANE HISTORY.....4

 A. FROM EARLY DAYS TO WORLD WAR II.....4

 B. FROM WORLD WAR II TO THE PRESENT.....33

 C. FLYING AIRCRAFT CARRIERS.....51

III. THE SEAPLANE AS A CARRIER OF FIGHTER/ATTACK AIRCRAFT.....54

 A. POSSIBLE SCENARIOS TO USE SEAPLANE AIRCRAFT.....54

 1. The Falklands War.....54

 2. The Attack on Libya.....61

 B. FIGHTER/ATTACK AIRCRAFT SIZING CONSIDERATIONS.....65

IV. SEAPLANE CONSIDERATIONS.....74

 A. GROSS WEIGHT.....74

 B. HULL CONSIDERATIONS.....76

 C. POWER DETERMINATION.....79

 D. RANGE AND ENDURANCE.....79

 E. COMPARISON WITH OTHER GIANT AIRCRAFT PROJECTS.....80

 F. RE-EVALUATION OF SEAPLANE SIZING.....81

 G. POSSIBLE SEAPLANE OPERATIONS.....83

 H. SEAPLANE CONFIGURATION.....83

V. SUMMARY.....86

APPENDIX MISSION PLANNING.....87

LIST OF REFERENCES.....96

INITIAL DISTRIBUTION LIST.....98

LIST OF FIGURES

1.1	PBN-1 CATALINA FLYING BOAT (from Ref.1, Pg.287).....	3
2.1	THE SOPWITH BATBOAT AT MONACO IN 1914 (from Ref.2, Pg.57).....	6
2.2	CAPRONI Ca 91 (from Ref.2, Pg.81).....	7
2.3	PEMBERTON-BILLING PB1 (Ref.2, Pg.72).....	8
2.4	SHORT 184 (Ref.2, Pg.30/31).....	9
2.5.	SEAPLANE CARRIER HMS ARK ROYAL (Ref.2, Pg.21).....	10
2.6	WANSA W12 (Ref.2, Pg.34).....	11
2.7	DORNIER RS III.(Ref.2, Pg.32).....	12
2.8	FELIXTOWE F.2A (Ref.2, Pg.38).....	12
2.9.	MARTIN MS-1 (Ref.2, Pg.38).....	14
2.10	MARTIN T3M DROPPING A 46-CM TORPEDO (Ref.2, Pg.38).....	17
2.11	US NAVY CURTISS CR-3 A6081 (Ref.2, Pg.53).....	18
2.12	DOUGLAS DT-2 (Ref.2, Pg.37).....	19
2.13	ARADO AR 95 A-1 (Ref.2, Pg.46).....	21
2.14	DORNIER Do X 1929 (Ref.2, Pg.83).....	22
2.15	BLACKBURN IRIS V (Ref.2, Pg.80).....	25
2.16	SUPERMARINE STRANRAER (Ref.2, Pg.89).....	28
2.17	130 FLYING BOAT CHINA CLIPPER (Ref.2, Pg.94).....	28
2.18	BLOHM UND VOSS BV 138B - 1 (Ref.2, Pg.106).....	29
2.19	MAYO/MERCURY SYSTEM (Ref.2, Pg.91).....	31
2.20	CONSOLIDATED PB2Y - 2 CORONADO (Ref.2, Pg.99).....	32
2.21	BLACKBURN B 20 (Ref.2, Pg.110).....	34
2.22	NORTHROP N - 3PB (Ref.2, Pg.47).....	35
2.23	YOKOSUKA E 14Y (Ref.2, Pg.51).....	35
2.24	US NAVY MARTIN MARS (Ref.2, Pg.114).....	37

2.25	NAKAJIMA A6M2 - N (RUFÉ) (Ref.2, Pg.51).....	38
2.26	SUPERMARINE SEA OTTER (Ref.2, Pg.115).....	39
2.27	AICHI M6A1 SEIRAN (Ref.2, Pg.51).....	40
2.28	A BOAC SHORT SONOLENT LANDING ON THAMES (Ref.2, Pg.106/107).....	41
2.29	SAUNDERS-ROE SR/A1 (Ref.2, Pg.120).....	42
2.30	GRUMMAN ALBATROS - SA-16 (Ref.2, Pg.121).....	43
2.31	MARTIN MARLIN P-5 (Ref.2, Pg.121).....	43
2.32	CONVAIR TRADEWIND (Ref.2, Pg.123).....	44
2.33	CONVAIR XF2Y - 1 SEA DART (Ref.2, Pg.124).....	45
2.34	MARTIN SEAMASTER (Ref.1, Pg.72-73-78).....	46
2.35	BERIEV BE - 12 TCHAIKA (Ref.2, Pg.126).....	47
2.36	UT-XS (EXPERIMENTAL AIRCRAFT) (Ref.3, Aircraft Division, Pg.5.....	48
2.37	PS-1 JAPANESE ANTI-SUBMARINE WARFARE AIRCRAFT (Ref.3, Aircraft Division, Pg.5).....	48
2.38	SHORT SANDRINGHAM (Ref.2, Pg.107).....	48
2.39	PS-1A - THE WATER BOMBER MISSION (Ref.3, Pg.27).....	50
3.1	A VICTOR LANDING IN WIDEAWAKE (Ref.4, Pg.286).....	56
3.2	THE BLACK BUCK OPERATION (Ref.4, Pg.286).....	58
3.3	SHRIKE MISSILE (Ref.4, Pg.284).....	59
3.4	THE VULCAN IN AN EMERGENCY LANDING IN RIO (Ref.4, Pg.288).....	60
3.5	THE TARGETS IN LIBYA (Ref.5, Pg.18).....	61
3.6	THE ONLY AVAILABLE ROUTE TO LIBYA (Ref.5, Pg.19).....	63
3.7	F-5E PRINCIPAL AIRCRAFT DIMENSIONS (Ref.6, Pg.1-5).....	66
3.8	VIEWS OF THE F-5E (Ref.7, Pg.398).....	68
3.9	SAMPLE MISSION PLANNING LOG FOR F-5E (Ref.8, Pg.A10-5).....	69
3.10	HI-LO-HI INTERDICTION PROFILE MISSION - F-5E (Ref.8, Pg.A10-7)....	70

3.11	EXTENDED HI-LO-HI INTERDICTION PROFILE MISSION (Ref.8, Pg.A10-7)..	71
3.12	FRONT LRS ENGAGEMENT POSITION IN THE F-5E (Ref.6, Pg.1-66).....	71
3.13	REAR LRS ENGAGEMENT POSITION IN THE F-5E (Ref.6, Pg.1-79).....	73
4.1	LAYOUT OF A HYPOTETICAL FLYING BOAT (Ref.9, Pg.96).....	77
4.2	SOME FLYING BOAT HULLS (NACA TN 1686) (Ref.9, Pg.A128).....	77
4.3	GIANT SEAPLANE PROPOSED BY SHIN MEIWA COMPANY (Ref.10, Pg.45).....	84
4.4	UPPER SURFACE BLOWING (USB) (Ref.11, Pg.136).....	85
4.5	USB FLOW CHARACTERISTICS (Ref.11, Pg.154).....	85

LIST OF TABLES

I. FIGHTER/ATTACK AIRCRAFT SELECTION.....65

II. U. S. COMMERCIAL TRANSPORT AIRCRAFT.....75

III. U. S. GAS TURBINE ENGINES.....78

ACKNOWLEDGMENTS

I would like to express my gratitude to Dr. Max F. Platzer, whose valuable guidance and help enabled me to complete this work.

To my wife Nilza, I would like to offer my thanks and love for her patience and understanding.

To my kids Sergio, Sandra and Patricia, the first readers of this work, I would like to express my gratitude for their help with grammatical corrections.

I. INTRODUCTION

It was the belief of some of the earliest visionaries and experimenters that it would be safer to attempt to fly over water than over land. The first such pioneer was Leonardo da Vinci who not only suggested the testing of a flying machine over a lake but advised on safety equipment also.

The seaplane meets some of the conditions of a boat or ship and of an airplane. To function properly, it should amalgamate these conditions to the advantage of each. None of its features of flotation should compromise those of airworthiness, and vice versa. During the operation of a seaplane on the water, we are confronted with ship problems; in its take-off and landing, there are both ship and airplane problems; and in the air, the matter is primarily one concerning aerodynamics.

Several seaplane experiments were accomplished toward the end of the last and in the beginning of this century, mainly in the pre-war years and during the First World War. A number of research and development projects were undertaken and new concepts were developed. Also, several operations were carried out, the attack against Zeppelin sheds by Short and Avro 504 aircraft, based on the carriers Ark Royal, Riviera, Empress and Engadine, or the first torpedoing of an enemy ship from the air, in Injeh Burnu, etc.

The decades from 1920 to 1940 saw the development of flying boats and of the bases from which they operated. It was also a period of exploration and improvement of the details necessary to efficiently operate them. Civil and military organizations forged ahead with design and operational improvements and, as a result of their joint efforts, airlines and service bases were established in locations not previously developed for use by other aircraft.

Until about 1940 the position of seaplanes and flying boats in both military and civil aviation seemed unassailable.

Seaplanes were used in a wide variety of military actions by all major combatants in every sector. Seaplanes flew patrols, attacked submarines and surface ships, transported troops and hardware, performed all sorts of bombing missions, and sometimes even worked as fighters.

During and immediately following World War II, however, this position no longer appeared as secure. While technical and scientific reports continued to support the development of water-based aviation, fleet purchases and military deployments increasingly favored the use of land or carrier aircraft. The building of airports in previously inaccessible locations around the world during World War II was a major reason for the transition from flying boats to land transports.

Also, difficulties with servicing aircraft on water compared to the relative comfort of hangars and dry land for ground personnel, inconveniences and delays long experienced by passengers boarding or disembarking seaplanes compared to the ease and speed of ground terminal facilities, the increased speeds of land planes and the larger number of passengers carried, all favored land planes and maximized profits. Thus, the end of the war in 1945 saw the significance of seaplanes in aviation declining rapidly.

If the military and commercial significance of seaplanes decreased after World War II, their importance was fundamental for Search and Rescue (SAR) and/or aeromedical evacuation in many parts of the world, mainly in countries with continental territories like Brazil, where particularly the PY2 Catalina and the SA-16 Albatros have made history and strongly helped in the Amazonic integration. The Catalina is flown regularly in northern Brazil, mainly in

the states of Amazonas and Para, whose area comprises about 1/3 of Brazil and where some of the biggest rivers of the world are located. It is used to transport medicines, food, tools, people, animals, books, letters, fuel, and so on.

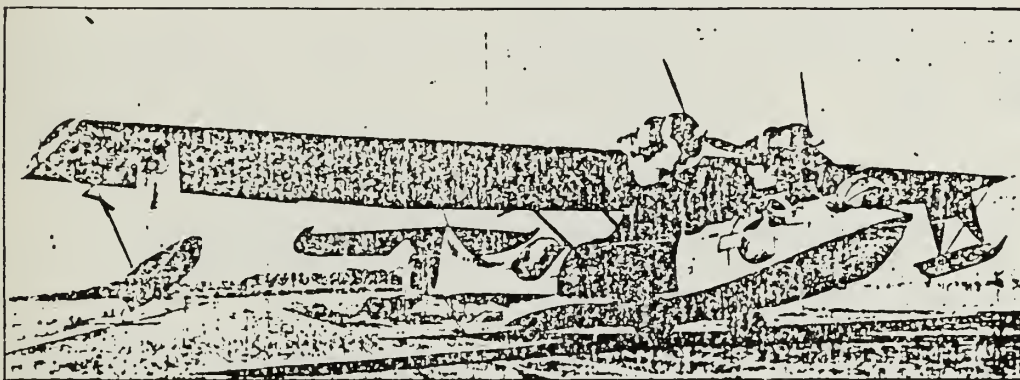

Figure 1.1. Catalina Flying Boat

The Albatros SA-16 was used mainly for Search and Rescue missions and, very reluctantly, was put aside when its lifetime was reached. In a tropical country, inundations occur very frequently and the SA-16 certainly rescued hundreds and maybe thousands of people.

In the military field, the seaplane has been virtually phased out by most countries. It is the objective of this thesis to take a fresh look at the military potential of the seaplane. To this end a detailed history of past seaplane developments is first given, followed by a proposal to use giant seaplanes as carriers of fighter-attack aircraft.

II. THE SEAPLANE HISTORY

A. FROM THE EARLY DAYS TO WORLD WAR II

The idea of using the water for tak-off and landing is very old indeed, having been suggested by Leonardo da Vinci.

In 1869, Emmanuel Farcot, a Frenchman, was granted a patent for various improvements to ships, consisting of a series of inclined planes along the sides of the ships with variable angles.

In 1878, John Stanfield and Josiah Clark of London proposed a new method of raising vessels or other moving bodies out of the water in order as to increase their speed.

In 1888, an American, G. W. Napier, patented a scheme for varying the draught of the ships by means of adjustable fins on each side of the vessel. Another American, C. E. Emery, applied in 1890 for a patent referring to retractable and adjustable surfaces, and in England, during the year of 1892, Sir Hiram Maxim patented a "high speed steamer" to "skim the water surface."

By 1893, an 8-HP steam engine was fitted to a Tissandier "glider" boat, with a propeller under water having a speed of 23 km/hour.

In 1895, Clement Ader, one of the most controversial figures in early French aviation, constructed a model craft with adjustable foils, two foils in the front, and adjustable from the inside to any desirable angle, a single adjustable foil in the rear, forming the tail.

By 1903, Samuel Pierpont Langley's "Aeromarine" came to grief on the Potomac. This model, after extensive modification and fitting with floats was made to fly by Glenn Curtiss, in 1914.

Almost all books about marine aviation mention Glenn Curtiss as the greatest pioneer of early marine aircraft developments.

Wilhelm Kress proposed the idea, in the early 1890s, to use Lake Keuka for experiments. It was from there that Curtiss on March 12, 1907 flew the first powered aircraft produced by the Aerial Experiments Association, of which he became "director of experiments." He followed this up with many other experiments with float planes and flying boats on Lake Keuka.

The first take-off from a ship was accomplished from a specially constructed platform over the foredeck of USS Birmingham on 14 November 1910.

By 1911, on January 26th, Glenn Curtiss became the first man ever to fly off and land on water, in San Diego Bay, California, in his "Curtiss-Ellyson hydroplane."

On 17 February 1911, at San Diego Bay, the Curtiss aircraft was lifted on board of the USS Pennsylvania and thus became the first aircraft to be recovered at sea.

On November 18, 1911 CDR Oliver Schawnn became the first British to takeoff from water, in Windemere, in the "Waterbird," a Curtiss-type float plane built by A. V. Roe.

Because of these early successes the first military hydro aircraft, the Curtiss A-1, was delivered to the U.S. Navy, still in 1911, and followed by the new model A2-OWL.

By 1912, several variations of the float plane design appeared and some of the new Borel aircraft, an 80-HP float plane, were purchased by the British Royal Naval Air Force.

Also, in this year, 1912, the big monoplane Guidoni was built and flown in Italy. It was 50 feet long and had a wing span of 66 feet. It was propelled by two 200-HP Gnome engines and was able to lift 9400 pounds of gross weight. It made history by dropping the first torpedo, two years after it was built.

The year of 1913 brought other manufacturers into the hydro arena. Burgess produced a hydro version of the Wright biplane and Frank Coffyn added a pair of multi-stepped floats to Russell Alger's Wright. Burgess also tested, in January, a military hydroplane which featured an enclosed fuselage.

In the same year, in Britain, the Sopwith Bat Boat, an amphibious aircraft, was produced, whose hull resembled a conventional boat hull in configuration, with a sharp bow, in contrast to the Curtiss hulls of this date.

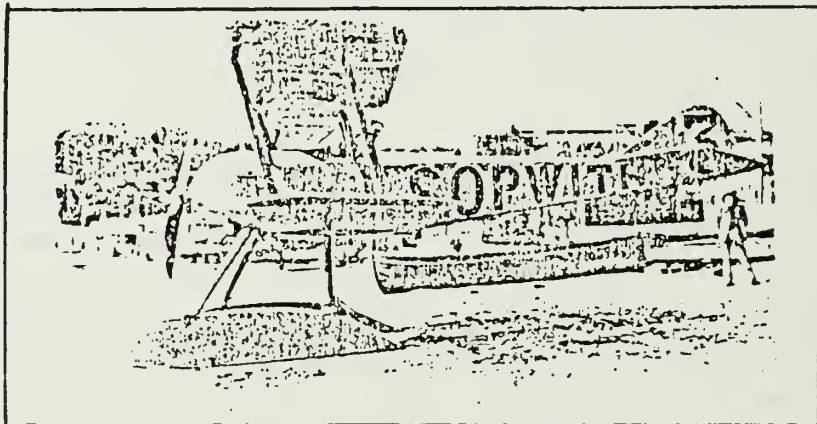

Figure 2.1 The Sopwith BatBoat at Monaco In 1914

On 8 July 1913, Harry Hauker and Lieutenant Spenser Gray, as an official observer, won the Singer prize in a Sopwith Bat Boat, which was the first amphibian aircraft in the world, Figure 2.1.

By October 26th, Mr. Winston Churchill formulated the types of aeroplanes he considered to be most suitable for the Royal Navy, recommending an "overseas" fighting seaplane to operate from a ship as base. The value of Mr. Churchill's foresight was to be emphasized by 1914 when the peace between Great Britain and Germany was broken. After the outbreak of war, the Royal Naval Air Service could muster 52 seaplanes and 39 aeroplanes, flown or maintained by a hundred officers and some seven hundred non-commissioned officers and men.

In 1914, the tail surfaces were mounted on the extreme rear structure of the hull, as in the case of the Curtiss H-1 America and in the Caproni Ca 91, a large flying boat of mixed construction, Figure 2.2.

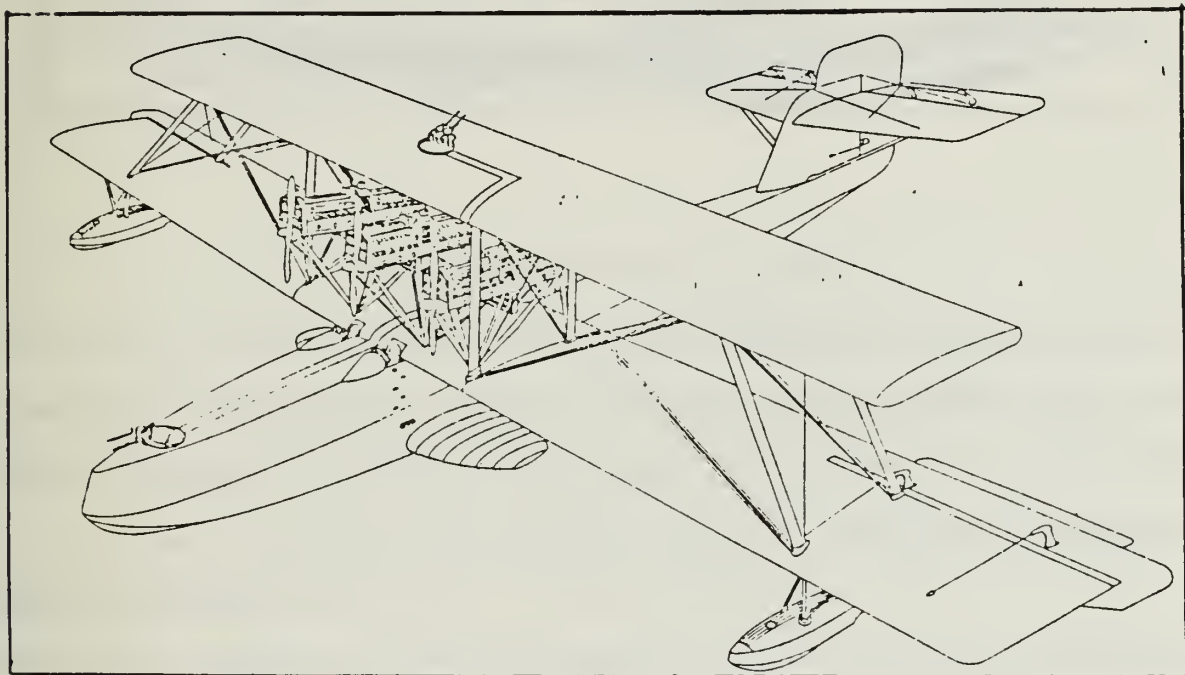

Figure 2.2 Caproni Ca 91

In the same year, a 100-HP Gnome-powered Henry Farman floatplane was built with twin floats attached to the hull by a spring device to minimize operating shocks.

The history records that another flying boat, the Benoist was used to inaugurate the first regularly scheduled airline—the St. Petersburg-Tampa Airboat Line, early in 1914.

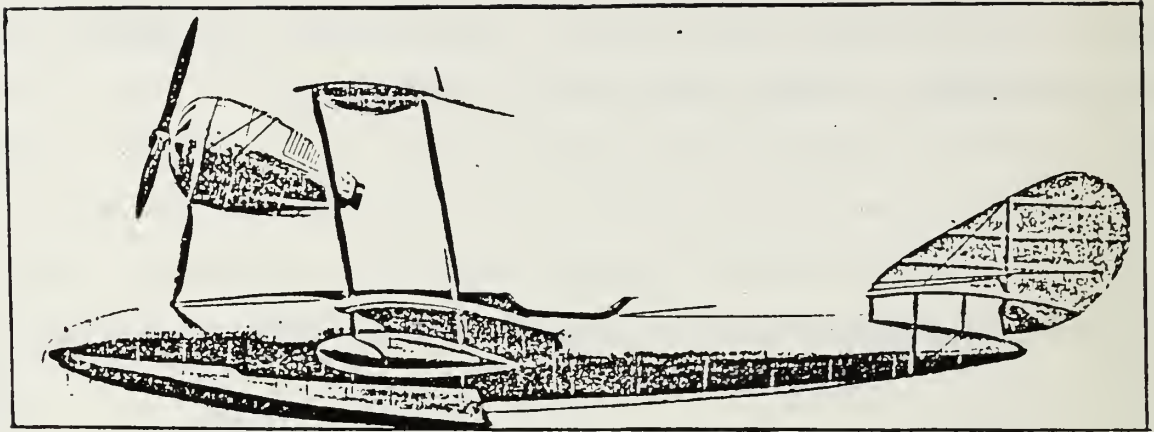

Figure 2.3 Pemberton-Billing PBl

In Europe, the British 1914 Pemberton-Billing PBl, Figure 2.3, otherwise known as the Supermarine PBl, was aesthetically very appealing. It was powered by a 50-HP Gnome rotary engine that was able to propel it through the air at 40-mph (80.5 Km/h).

In 1915, the first full year of the war, several improvements were made on the existing seaplanes, mainly concerning the use of torpedoes to be launched from the air.

On 12 August, Flight Commander C. H. K. Edmonds, flying a Short 184 from the Gulf of Xeros, sighted a large Turkish merchant ship off Injeh Burnu and dived to a height of some 15 feet above the water, launching his torpedo at a range of 300 yards. The vessel was hit amidship, and Edmonds thus became the first man in history to torpedo an enemy ship from the air. Five days later, on 17 August, he torpedoed one of three large supply ships he spotted heading for the Port of Ak Bashi Liman, while Flight Lieutenant G. B. Dacre also scored a success by topedoing a Turkish steam tug in False Bay, from a Short 184/1845 prototype.

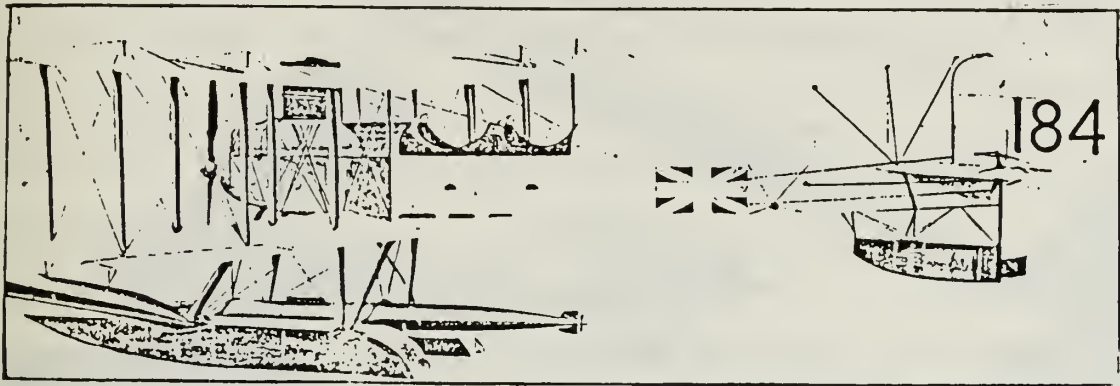

Figure 2.4 Short 184

Still in 1915, the 7450 ton Ark Royal, designed as a merchant ship and converted to be a seaplane carrier, lived up to this task by carrying ten short floatplanes. This kind of floatplane was able to carry three 51-Kg (112-lb) bombs or a 35.6-cm (14-inches) torpedo with a Lewis gun for the observer, Figure 2.5.

In the same year, the first successful flight using a catapult was made, on April 16th, by Lieutenant P. N. L. "Pat" Bellinger, flying a Curtiss F (Navy C-2/AB-2) flying boat.

In the same year, on Christmas Eve, after three raids over German territory by other kind of aircraft, mainly the Avro 504, the seaplane carriers Riviera, Empress and Engadine, each one with three Short aircraft below decks launched an attack the next morning against the Zeppelin sheds. The nine floatplanes were hoisted out and went skimming away. Seven of these Short biplanes rose without any difficulty but two of them refused to become airborne with their heavy weight of bombs and had to be swung back aboard their parent carriers.

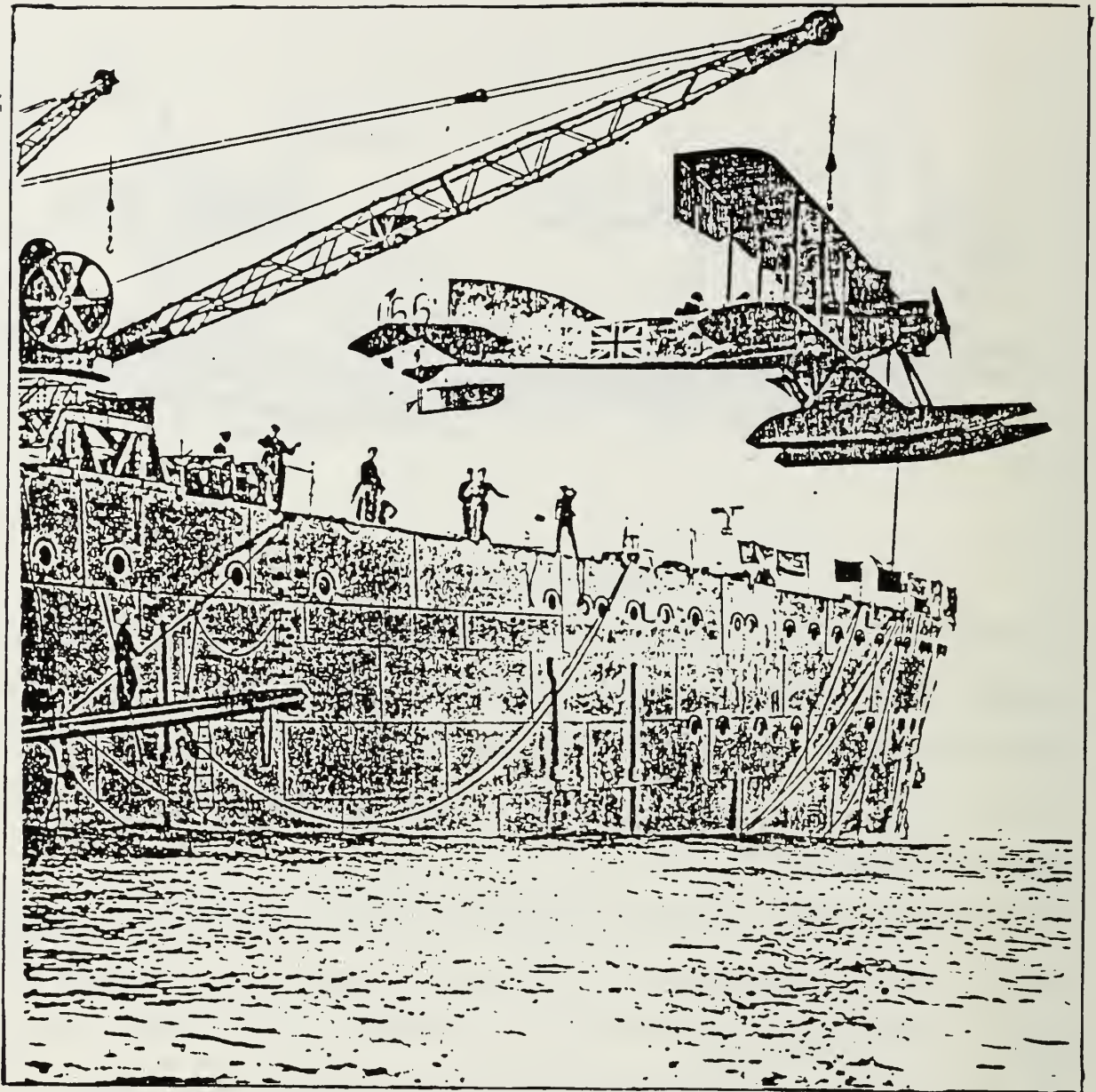

Figure 2.5 - Seaplane Carrier HMS Ark Royal

By 1916, the first aircraft type to use wing-folding in combat operation, the Short 184s, were embarked in seaplane carriers and participated with distinction in the Battle of Jutland on May 31.

In the same year, two interesting float-plane designs appeared: the Brandenburg biplane, a German design, and the Austrian Sablatnik triplane Scout.

By 1917, in England, the First Lord of the Admiralty, Sir Winston Churchill, defined in a directive the correct designation for the flying water-craft and the term seaplane was to apply to float-equipped aircraft. The term flying boat was to apply to aircraft whose fuselage was in fact a boat-like hull. Simultaneously, there began a change in the structure of these water-craft.

In Italy, in keeping with previous products and practice the Caproni company produced a giant triplane hydroplane, the Caproni 43, and a twin-engine biplane hydro Model 47.

In Germany, another seaplane, the HANSA-W12, Figure 2.6, a wooden two-seater scout fighter was put in service, powered by a 160-HP Mercedes D3 or 150-HP Benz Bz3 engine, developing a 160-Km/h maximum speed with 3 1/2 hours of endurance and one or two 7.92-mm Spandau machine-guns with a flexible Parabellum.

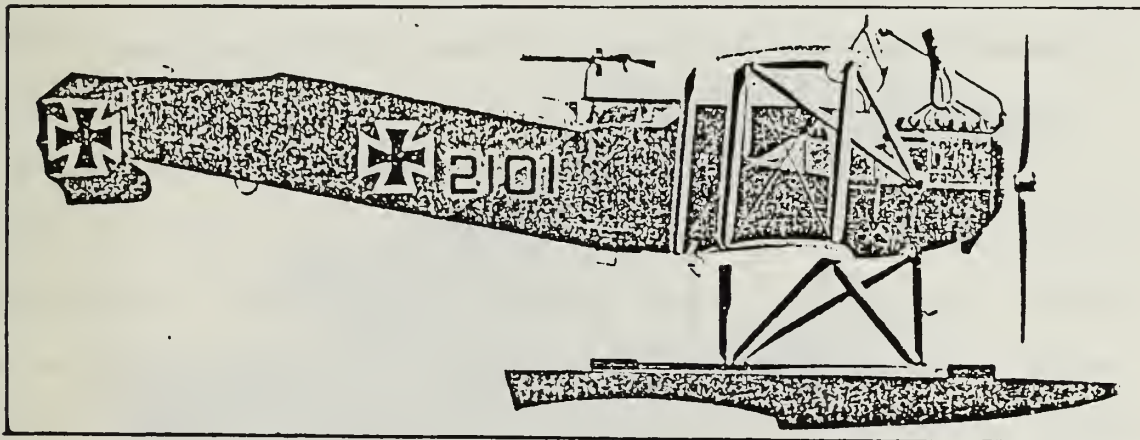

Figure 2.6 - Hansa W12

Still in Germany, in the same year, the square fuselage of Dornier Rs III was positioned above the wings to keep the tail surface as far above the waterline as possible which facilitated the mounting of armament and proved easy to fly, as shown in Figure 2.7, below.

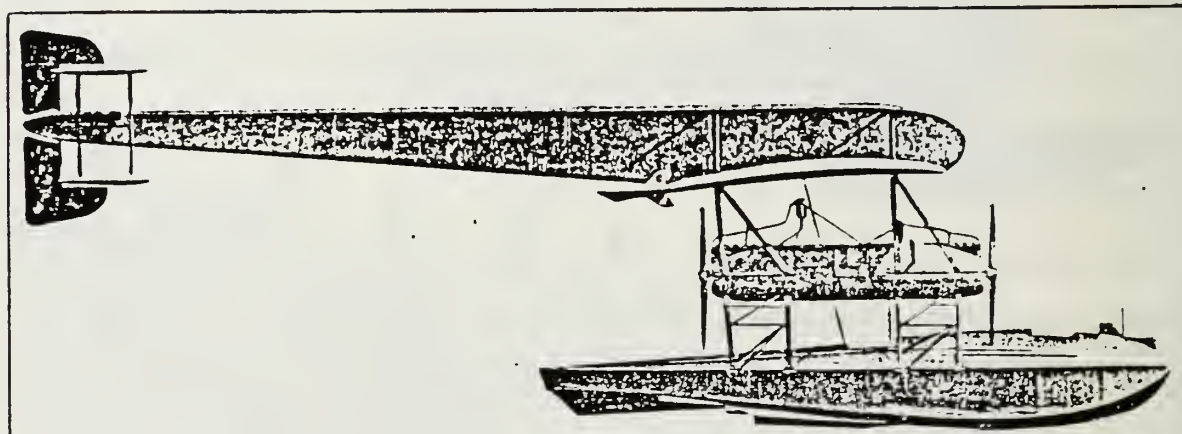

Figure 2.7 - Dornier RS III

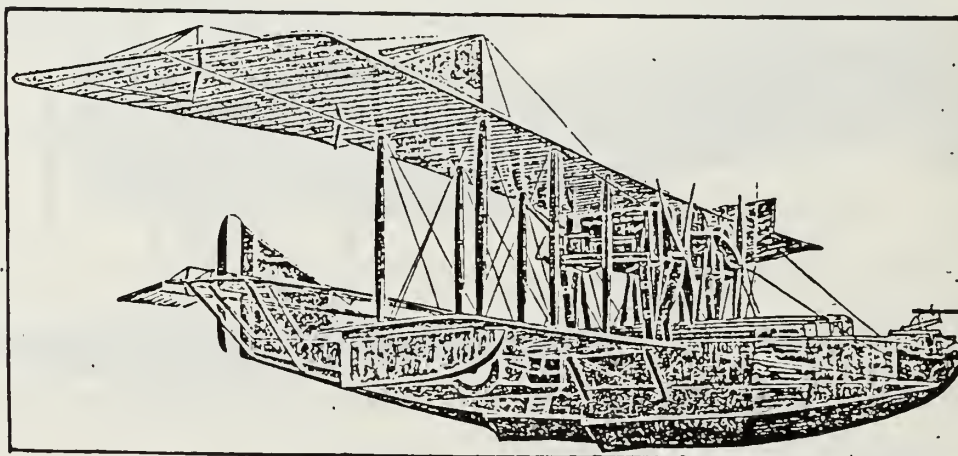

Figure 2.8 - Felixtowe F. 2A

In England, the Felixstowe F2A.s, powered by a 2345-HP Rolls-Royce Eagle VIII was used for antisubmarine patrol in the English Channel and the seas around the UK. At that time, the F.2/F.2A were among the largest aircraft in operation, Figure 2.8.

By 1918, the Brandenburg floatplane designed two years before was modified to give the observer-gunner a clear field of fire to the rear, removing any possibility that the gunner, in the excitement of combat, would shoot up his own tail surfaces.

By 1919, the Spad firm produced the high performance racing plane for the Schneider Cup race and the "Cannon Spad" for the French navy. This model incorporated a 77-mm (3-in) gun synchronized to fire through the arc of the propellers, for hunting submarines in coastal waters.

In the same year, after extensive preparation and the stationing of a fleet of destroyers along the route from Newfoundland to the Azores, three NC-4s plodded along at a modest 78-mph (125.5-Km/h) to become the first aircraft to bridge the Atlantic, crossing from Rockaway Naval Air Station, Long Island, via Trepassy, Newfoundland, and the Azores to Lisbon and Plymouth, England. They began on 8 May 1919 and arrived 23 days later, after an elapsed flying time of 53 hr and 58 min.

By 1920, the aircraft manufacturers who had survived the drastic production cutbacks that followed the war years were grasping for business and some companies, such as the Short Brothers, developed all purpose designs, such as the Shrimp, a seaplane with a number of unusual features. It was designed for civil or military use and at least two engine options, namely a 160-HP Beardmore for economic operation in training or observation duties and a larger 240-HP Siddeley Puma for maximum performance military use and commercial charter work.

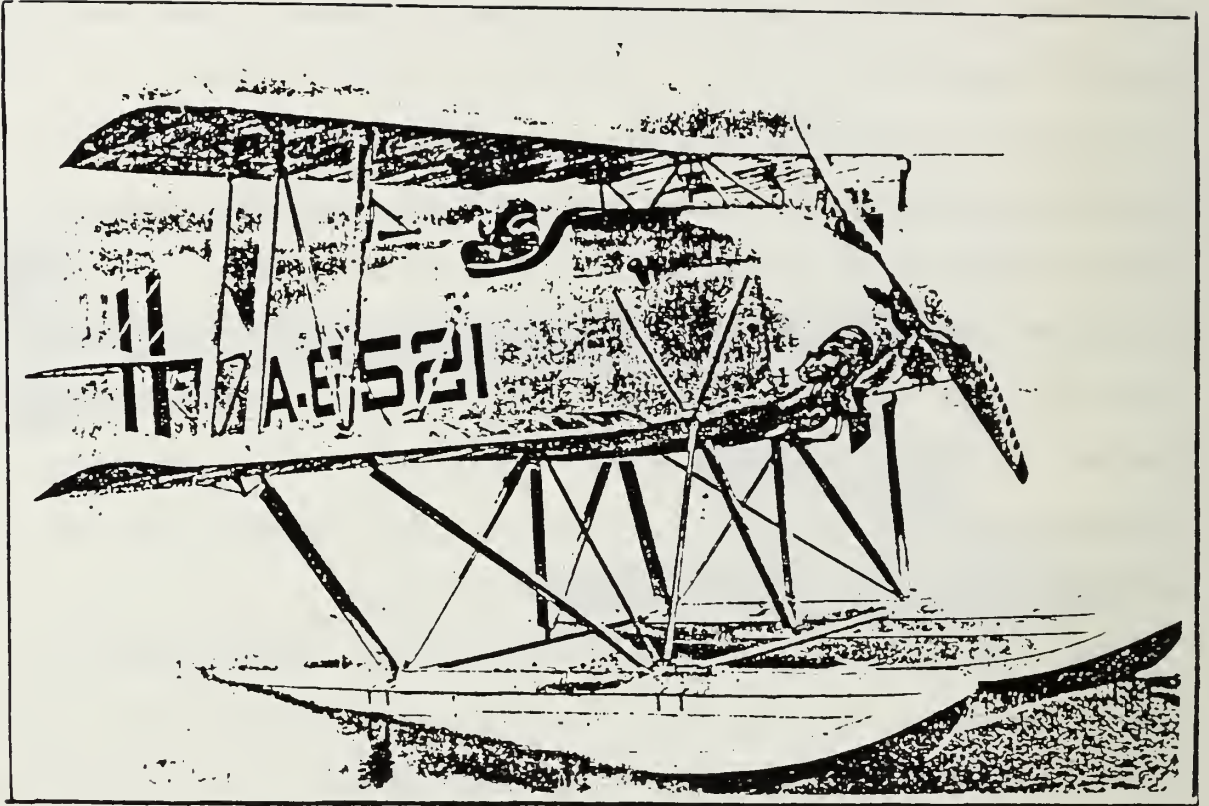

Figure 2.9 - The Martin MS - 1

In the same year, the Martin MS-1 seaplane, Figure 2.9, was built to be submarine-launched. This tiny aircraft, stowed in a hangar built into the submarine conning tower, allowed the captain to send out a spotting aircraft to locate likely targets. The concept was widely developed during the mid-1920s.

In the 1920 and 1921 Schneider races, seaplanes were barely in the running as flying boats dominated the races and the US Services had entered air racing as a means of developing improved technology for application to service aircraft.

The Schneider Cup, properly recorded as La Coupe D'Aviation Maritime Jacques Schneider, was to become the major incentive for the development of float-type hydroplanes. It was to be an international race, sanctioned by the Federation Aeronautique International (FAI) and open to any FAI-affiliated national aviation club. The winning club of each annual contest was to hold the trophy and be host for the contest to be held the following year.

By 1921, Italy fielded a race team and this time the Macchi M-7 was the victor at 117.8-mph, putting the Italians on the verge of taking permanent possession of the Schneider trophy.

The Caproni Ca 60, built between 1919 and 1921, a triple-hydro-triplane flying boat with eight 400-HP Liberty engines developed a total of 3,000-HP and was designed to carry 100 passengers. However, in the second test flight on 4 March it had a bad landing with major damage forcing the cancellation of the project.

During this time, one of the most highly regarded fighter aircraft in the British service was the Fairey Flycatcher, often known as the "indestructible" because of its rugged structure. The design incorporated fittings for the attachment of floats.

The Fairey Type III emerged to become one of the most successful designs of this period and a special version, the FIII Transatlantic, was fitted out to become the first to attempt the crossing of the South Atlantic in 1922. Captain Saccadura Cabral and Captain Gago Coutinho of the Portuguese navy succeeded in flying from Lisbon, leaving on 30 March, 1922 to St. Johns Rocks off the South American coast on the Equator. Unfortunately, a bad landing put an end to the aircraft and deprived the crew of the distinction of completing

the flight as originally planned and the final stage of the flight from St Johns Rocks to Recife, Brazil was made in a Standard Fairey III D of the Portuguese navy.

The 1922 race was held in Naples, Italy, with another Italian victory a very real possibility. This time, however, it turned out to be a British victory won by H. C. Baird piloting the Supermarine Sea Lion II, at an average speed of 145.7-mph (234,5-Km/h). This was the last time the race was won by a flying boat.

In this same year the Dornier J or Wal (Whale) made its first appearance. This was to be one of the workhorse designs of the 1920s. Its lines were teutonic and its performance, with a variety of engines, was always to be admired. Its descendant, the Dornier Do 18, saw service as recently as World War II. Designed in the period of the prohibition of aircraft construction by Germany, under the terms of the Armistice, the Wal was produced under licence in Italy, reaching at least 300 units, and was used by the military services of Italy, Spain and the Netherlands, while commercial use of this type was made by Lufthansa and Aero Lloyd, Aero Expresso in Italy, Varig in Brazil, SCATADA in Columbia and Nikon Koku in Japan.

In 1923, one of the most important events was the appearance of the Martin TM3 which was based on the Curtiss CS-1 torpedo-bomber. It could carry a torpedo or bombs and was armed with a 7.62-mm (0.30-in) machine-gun in the observer's position. The Figure 2.10 shows a Martin T3M dropping a 46-cm (18-in) torpedo during training in the late 1920s.

Still in 1923, Lieutenant David Rittenhouse, won the Schneider race at Cowes, England, with the Curtiss CR-3, Figure 2.11.

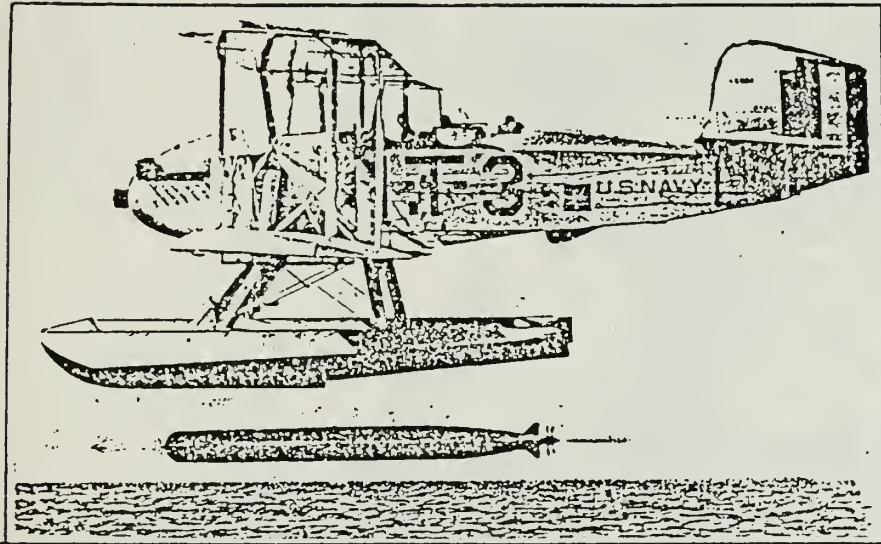

Figure 2.10 - A Martin T3M Dropping A 46-CM Torpedo

An aircraft design known as the DWC (Douglas World Cruiser), Figure 2.12, was derived from the US Navy DT torpedo plane and powered by Liberty engines, the standard US powerplant left over from the war.

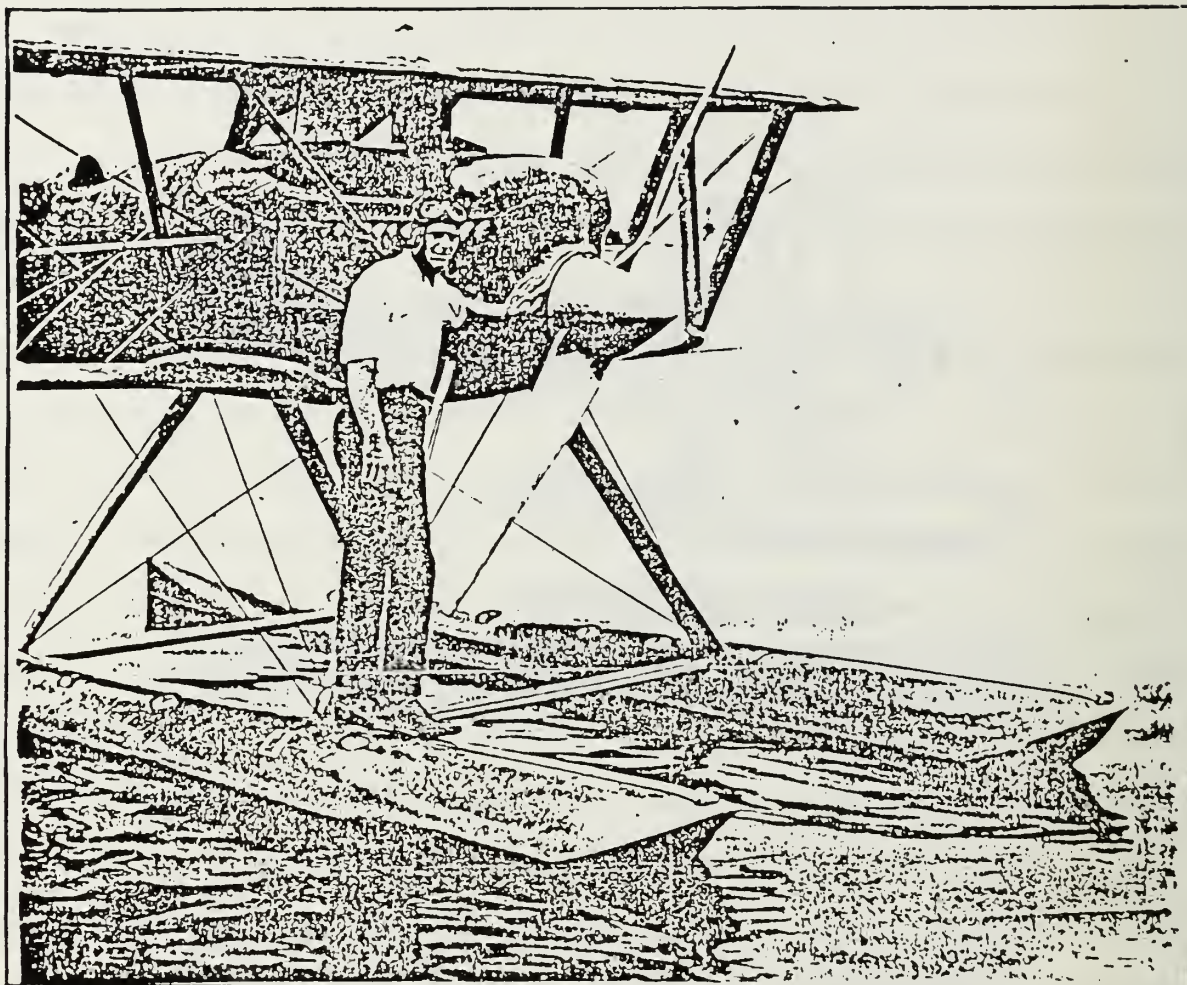

Figure 2.11 - US Navy Curtiss CR-3 A6081

The DWC was, like most seaplanes, adaptable to either floats or wheels and in 1924, four DWC accomplished the feat of circumnavigation of the Earth. Two of the DWCs made the complete trip and are presently exhibited in museums. The New Orleans 4 is exhibited in the US Air Force Museum at Dayton, Ohio, and the flagplane, Chicago 2, is exhibited in the US National Air and Space Museum in Washington, DC.

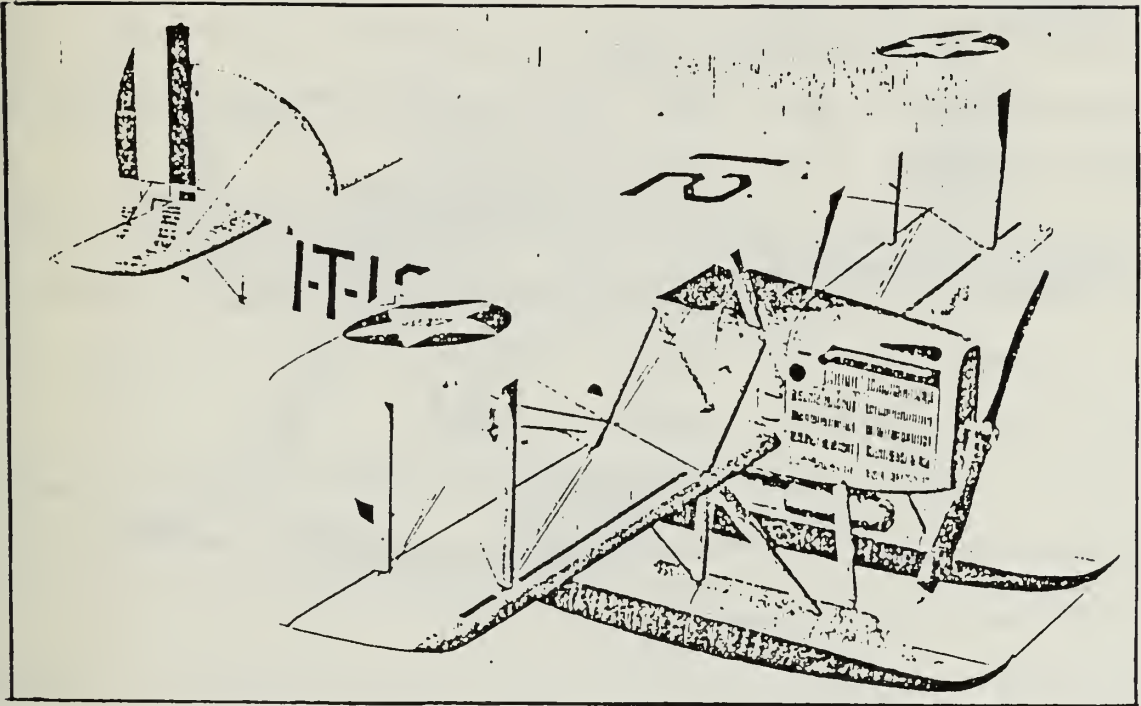

Figure 2.12 - Douglas DT-2

By 1925, one of the largest US orders for aircraft was the Martin SC2 torpedo-reconnaissance aircraft. As was the custom at this time, it was designed with interchangeable landing/sea alighting gear. The seaplane version had two floats to accommodate a torpedo.

From November 16, 1925 to March 13, 1926, Alan Cobham flew from London to Cape Town and back.

The 1926 Schneider race was an all-floatplane race and it had become apparent that the flying boat, even in its most highly developed form, was clearly not a match for the contemporary floatplanes as a racing machine.

Both the Italian and the US industries were experiencing developmental problems with the engines selected for the 1926 race. The Macchi M39, flown by Mario de Bernardi, won the contest at the average speed of 246.5-mph (396.7-Km/h).

Early in 1926, Major Franco, a brother of General Francisco Franco, made the first east-west crossing of the South Atlantic to Buenos Aires, Argentina, from Palos de Megues, Spain, in a Dornier Wal.

On 7 December 1926, Group Captain R. Williams, chief of the Australian air staff, began a survey flight of the mandated islands of the South Pacific in a DH50. The purpose of this survey was to acquire information on flying conditions and facilities in these territories.

With the increasing commercialization of aviation - 1927 and on - many small seaplanes came into use for sport and transportation.

In this same year the name "Arado" appeared in German aircraft circles and in the seaplane category, they built a training machine, Figure 2.13, below, which featured twin engines of very modest power, the Siemens-Halske SH-12 air-cooled radial of 110-HP. The large, highly-cambered, cantilever monoplane wing gave it wing loading and power loading in the same category as the Havilland Moth and the later Piper J-3 Cub aircraft.

By the end of the 1927 race it became obvious to all concerned that the development of worthwhile competitors for the race required more than 12 months. Therefore, at a meeting of the FAI, held in Paris on 5 January 1928, it was agreed to make the race a biennial event. On 29 February, the Royal Aero Club announced that the next contest would be held between 29 August and 5 October, 1929.

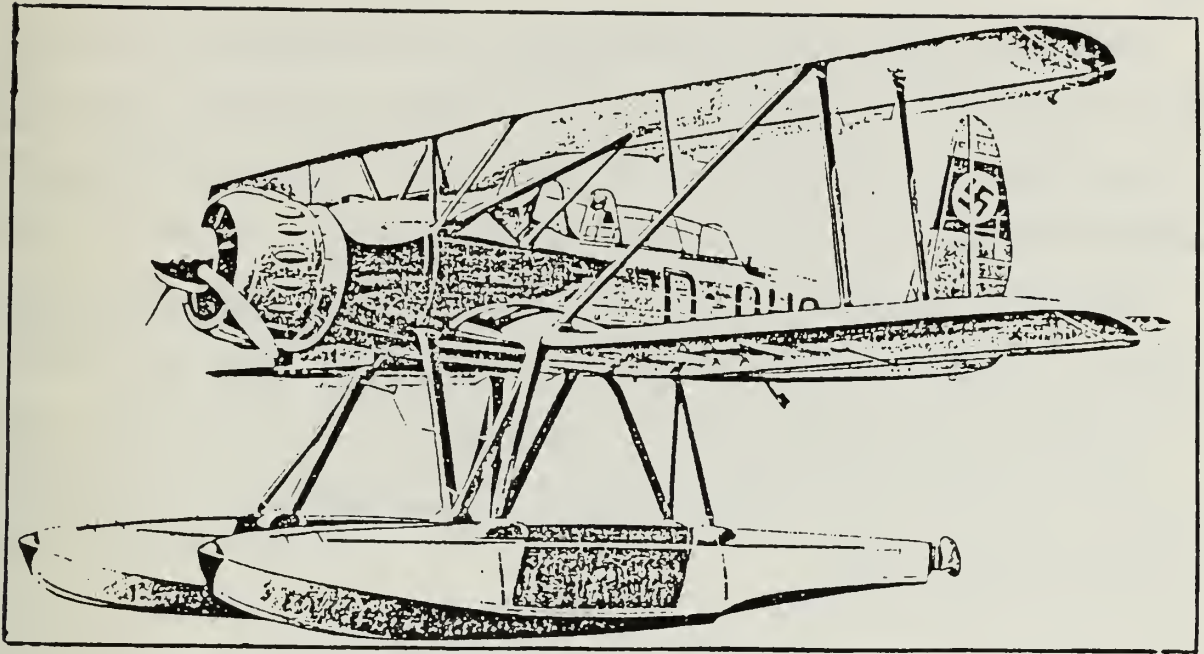

Figure 2.13 - Arado AR 95A-1

The 1929 Schneider race results were: Supermarine S6 at 328.65 mph (529-Km/h); Macchi M52R at 284.2 mph (457-Km/h) and the Supermarine S5 at 282.11 mph (454-km/h). The British team had won, ensuring that the 1931 race would also be held in British waters.

The Dornier Do X, which suffered from a number of mechanical problems and minor disasters during its service, has the distinction of being the first aircraft to carry 169 passengers as far back as 1929, Figure 2.14.

In 1930, the Dornier Do X went on a world trip which took it to New York via South America. On a trip from Amsterdam via Lisbon, Rio de Janeiro and Miami to New York, the Do X was dogged by troubles and took from 2 November, 1930 until 27 August, 1931 to complete the trip.

In August, Wolfgang Von Grunau successfully crossed the North Atlantic from Germany via Iceland, Greenland and New York on to Chicago, in a Dornier Wal.

After the success of the 1929 Schneider race, the spirits were high in Britain but financial support was low, so low that, contrary to expectations, the government declared that it had no intentions of providing the funds necessary to enter the 1931 race, due the 1929 recession.

The Italian team lost no time in beginning their own preparation of the aircraft on hand, the Macchi M67 and the tandem-engined Savoia S65.

The S65, during an attempt for a world speed record, on 18 January, 1930, plunged into Lake Garda, killing the pilot, Tomasso Dal Molin, who had piloted the Macchi M52R, in 1929.

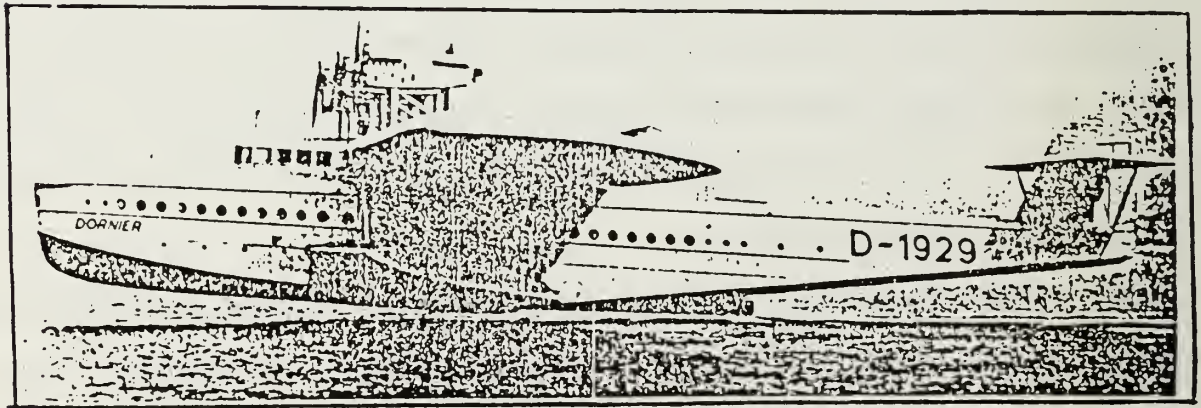

Figure 2.14 - Dornier Do X 1929

This left the M67 as a possible contender but in view of the 1929 experience it was decided to build a worthy successor. The Macchi-Castoldi MC72, was the result. The MC72 was to be powered by an unusual power plant, the Fiat AS6, developed from the lightweight AS5 engine, where two of these engines were coupled in tandem with the drive shaft of the rear engine nestled in the "V" between the cylinder blocks of the front engine. This rear shaft passed through the reduction gear of the front engine to drive one propeller and the front engine powered the second propeller independently of the first. The resulting duplex engine produced a take-off rating of 3100-HP per pound ratio. The first two MC72s experienced inflight difficulties, related to the unusual engine installations, causing crashes which destroyed the aircraft and killed their pilots.

Nine days before the designated date for the race, the Italian and French Aero Clubs approached the Royal Aero Club for a postponement. Although the US team had set a precedent for such a postponement in the 1924 race, the Royal Aero Club refused to postpone and decided to press forward with the race and to fly the course even if the other contestants were unable to be on hand to compete.

On the designated day of the contest, 13 September, 1931 only the British team was ready and at just two minutes past 13:00 hours, the S6B, S1595, was slipped into the water. Flight Lieutenant J. N. Boothman made the prescribed take-off and landing followed by a two-minute wait before taking-off for the first seven laps to win the 1931 Schneider race and retain the trophy, at an average speed of 340.08-mph, (547-Km/h). Later the same afternoon, Flight Lieutenant George Stainforth, flying the S6B, S1596, set a new 2-mile (3-Km) speed record of 379.05-mph (610-Km/h).

Two postscripts to the Schneider series are worth recording. The first was a special attempt to raise the speed record over the 400-mph (644-Km/h) mark. To do this, the S6B, S1595 was fitted with a special "sprint" engine which was fed a specially concocted mixture of 60% methanol, 30% benzol and 10% acetone.

On 29 September, Stainforth tried to better his own record, and his average speed was 408.8-mph (658-Km/h).

The second post-race development involved the Macchi MC72, flown by Francesco Agello. It established a seaplane record of 440.68-mph (709-Km/h), which was to stand until 1961.

The distinctive German designs of the mid-20s period bore the Junkers name who continued to produce a line of all-metal aircraft whose seaplane version is the Ju 52W, the standard work-horse of the Luftwaffe in World War II. In its early development, the Ju 52 was a single-engine aircraft, powered by an engine of 700-1000-HP. Two variations were powered by the Junkers 188 or BMW VII, both liquid-cooled engines, or the 700-HP Armstrong Siddeley Leopard air-cooled engine. The better known World War II version was, of course, the trimotor, the ubiquitous Ju 52/3m, which was developed in 1932.

The early 1930s was the era of transition from wood to metal structures and the Iris series was swept along with this tide.

The Iris V, built in 1933, was large and was powered by Rolls-Royce Buzzard engines, Figure 2.15. It became the prototype of the Perth.

In this same year, the US Navy ordered 23 P2Y-3s which had their Wright R-1820 engines mounted in the wing leading edge. Experience gained on these aircraft was to be useful in the design of the Model 28 which was to gain fame as the PBY-Catalina of World War II fame.

The Savoia-Marchetti companies had produced limited quantities for specialized racing or training aircraft. In 1934, the C.R.D.A. Cant Z.501 Gabbiano was introduced. In order to test this new aircraft, it was prepared for a record attempt and, in October 1934, flew non-stop from Trieste to Massawa, Eritrea, a distance of 2560 miles (4120-Km), to establish a record for this class of aircraft. Again, in July, 1935, a second flight from Trieste to Italian Somaliland increased the record distance to 3080 miles (4957-Km).

In 1935, the ARK-3 developed by I. N. Chetverikov, was produced as a multipurpose flying boat and designed to meet the needs of the undeveloped Soviet territory.

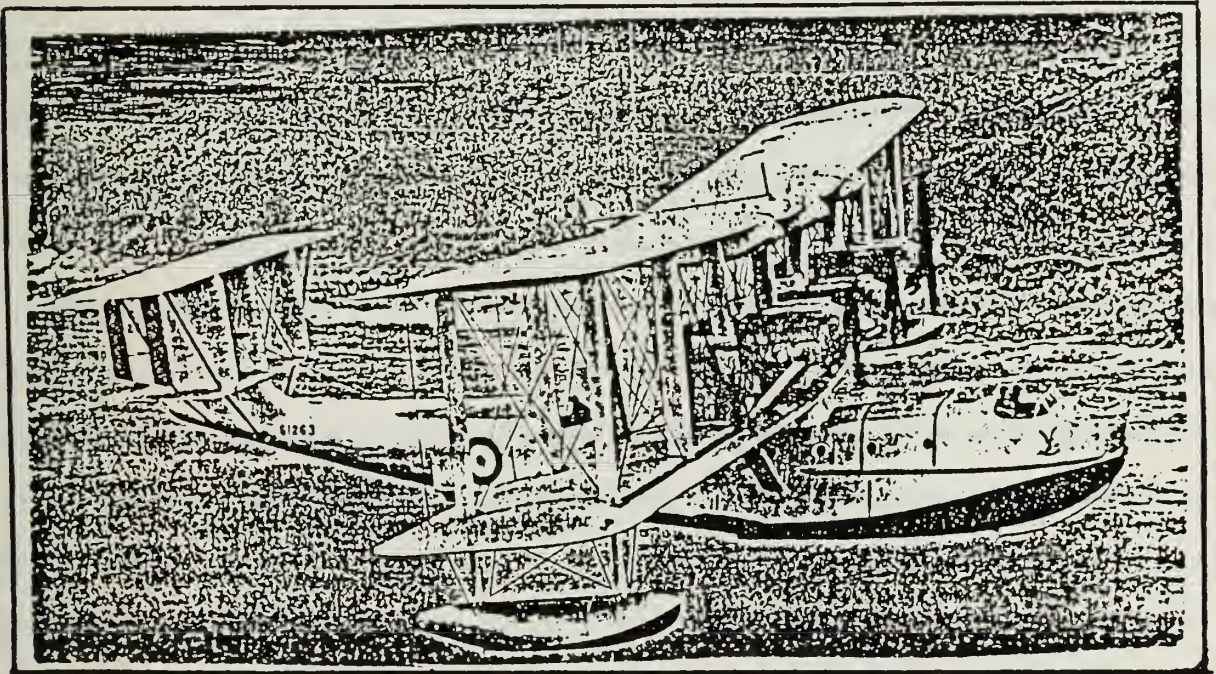

Figure 2.15 - Blackburn Iris V

In France, in 1935, Farman produced the F271, a monster twin-engine biplane torpedo/reconnaissance seaplane, featuring very square lines of fuselage, wing and empennage. In the same year the Latecoere 521 flying boat made its first flight. Powered by six 860 HP Hispano-Suiza twelve-cylinder V engines, it was a very large plane, seating 70 passengers on trans-Mediterranean and 30 on transatlantic flights. The French Navy flew three such planes, another three were used commercially. The maximum endurance was an impressive 33 hours. In 1938 the Latecoere 631 was produced. It was capable of carrying 60 passengers over 3728 miles. After the war six such planes were used by Air France on the transatlantic service.

On 14-15 October, 1935, Lieutenant J. K. Averill and a crew of four flew an XP3Y-1 from Cristobal Harbor, Canal Zone to Alameda, California in 34 hr 45 min, establishing two world records of 3281.2 miles (5280.7 Km) straight-line distance and a total of 3443 miles (5540,9 Km) overall distance.

The Supermarine Stranraer, Figure 2.16, which entered service in 1936, was the fastest of the biplane flying boats of the RAF. They were also the best protected in a structural sense, taking advantage of the preserving characteristics of the anodizing process then being introduced. It was particularly advantageous to marine aircraft which were always subject to corrosion from sea water.

In this same year, the Short Sunderlands were being built. Their design was based on the C class Empire flying boats which formed the backbone of Britain's Imperial Airways.

In USA, the Martin M-130 Clipper, a project design sponsored by Pan American Airways started the full transpacific service on 21 October, 1936, and took five or six days since rest stops were included in the schedule. Three aircraft were built and named China Clipper, Figure 2.17, Hawaiian Clipper and Philippine Clipper. Routing was from San Francisco via Hawaii, Midway, Wake, Guam, Manila and finally extended to Hong Kong in April, 1937.

The Martin 130 Clipper, although built in only small numbers, proved to be an outstanding aircraft. Therefore, the Martin Company initiated the design of a new flying boat, designated the Model 156. Although test-flown successfully, the outbreak of World War II brought an end to its development.

Pan American Airways, in 1935, also ordered six flying boats from the Boeing Company. Designated the Model 314, these aircraft accommodated a crew of eight and 74 passengers. Powered by four Wright Cyclone radial engines, the first flying boat flew on 7 June 1938 and transatlantic and transpacific service started in 1939. These aircraft proved entirely successful, prompting Pan American to order six additional improved versions, designated Model 314A. After the outbreak of the war these flying boats were transferred to the U.S. Navy.

In the early 1930's Pan American Airways was looking for a large, long-range flying boat and Igor Sikorsky was given the task of building three aircraft, designated the S-42. Powered by four 700 HP Pratt & Whitney Hornet radial engines, each driving a variable pitch propeller, the S-42 could accommodate a crew of six and up to 32 passengers. The three S-42s were followed by three S-42-As and four S-42-Bs, enabling Pan American to pioneer transpacific routes. As a result the S-42 has an honoured place in American aviation history.

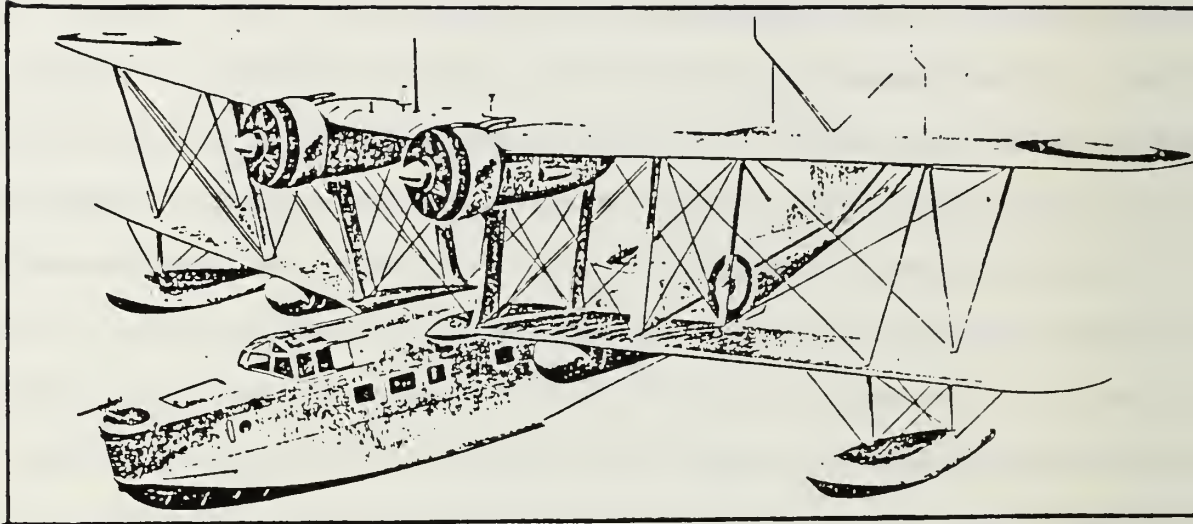

Figure 2.16 Supermarine Stranraer

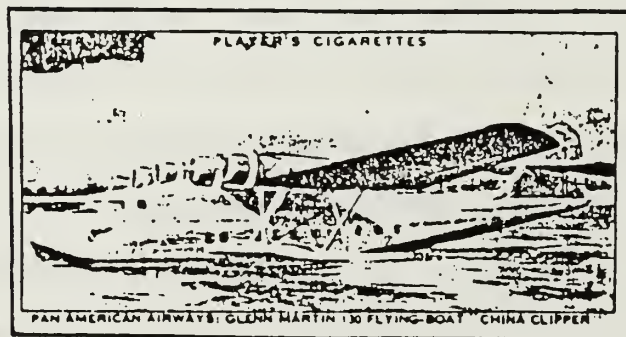

Figure 2.17 M-130 Flying Boat China Clipper

Still in April, 1937, the ARK-3, developed by I. N. Chetverikov, established a record for height and weight of 30,151 ft (9190 m), carrying a 1000-Kg (2204-lb) payload.

The Grumman Aircraft Company designed in this year a twin-engined amphibian which was ordered off-the-drawing-board by a number of private pilots and company executives. This was the Grumman G 21 Goose, a handsome and efficient six/seven place aircraft which proved to be popular in civil aviation and was acquired by the US Navy as a utility aircraft under the designation of JRF and by the US Army Air Corps as OA-9s.

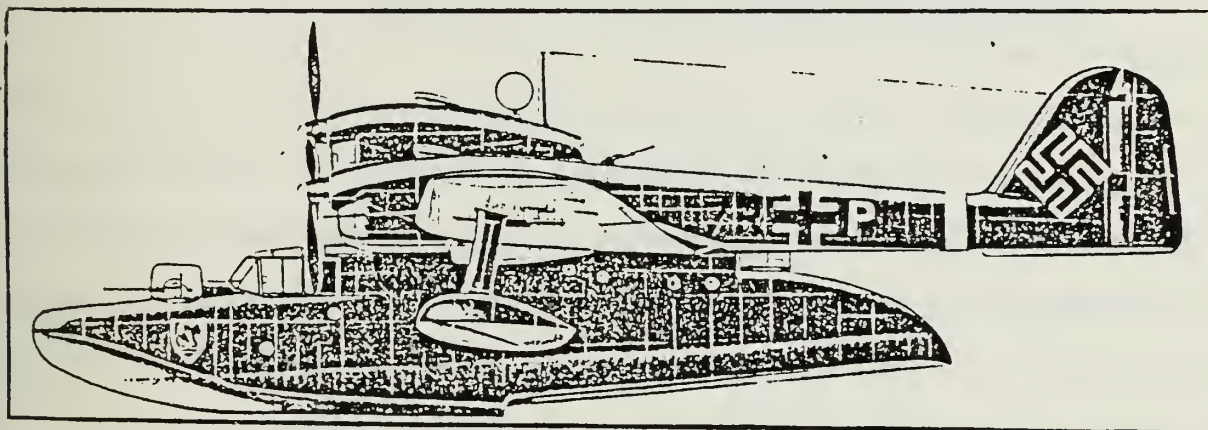

Figure 2.18 Blohm Und Voss BV 138B-1

As war approached in Europe, several flying boat designs emerged, probably in anticipation of a military conflict. The first of these was the Blohm und Voss BV 138 B-1, Figure 18, the "Flying Shoe" as it was known, whose geometry reverted back to the short hull/tail boom configuration of the Curtiss NC boats of World War I.

An interesting design was the Short-Mayo Composite, Figure 2.19, one single aircraft, christened Mayo, had a large planing bottom with a wide flare at the bow, to lift the increased weight and area of both the wing and the tail surfaces. In addition, the outboard engines were more widely spaced to accommodate the Mercury, a twin-float, four engined aircraft which was mounted on a frame above the center of the wing of the Maia.

Operationally, the Maia served to lift the Mercury to cruising altitude, at which time they would separate after the Mercury showed a positive lift capability, allowing the Mercury to proceed to its destination fully laden. One trip was made from Foynes, Ireland, to Montreal, non-stop on 21 July, 1938. A second flight, on 6 October, was made from Dundee to South Africa, a distance of 9728 Km (6044.7 miles) to establish an international distance record for seaplanes.

On the Japanese side, the Kawanishi H6K Mavis, appeared in January, 1938, to serve as long-range maritime reconnaissance bomber with a maximum speed of 529 Km/h (329-mph) and an endurance of 26 hours. Lack of armour protection and self-sealing fuel tanks made them extremely vulnerable to Allied fighters, Nevertheless, in reconnaissance or transport roles they proved to be very effective and remained in service until the end of the year.

The limitations of the H8K caused the Imperial Japanese Navy to issue specifications for a new flying boat with a maximum speed of 276 mph and a maximum range of 5,182 miles, superior to U.S. and British seaplanes. In response Kawanishi developed the H8K, which also had four engines, but partially self-sealing tanks, a carbon dioxide fire-extinguishing system, a 20 mm cannon, and five machine guns. The first flight was made in January 1941 and 167 planes were eventually produced. The H8K is remembered in Japanese aviation history as its best and largest flying boat.

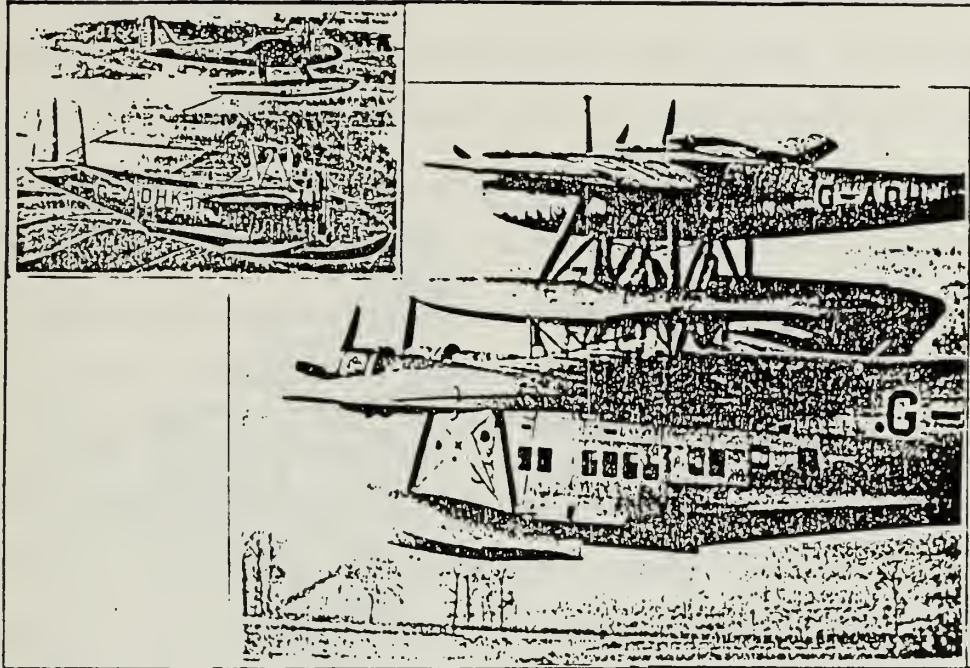

Figure 2.19 - Mayo/Mercury System

In the United States the XPBM-1, a twin-engine very large aircraft, powered by Wright R-2600 engines of 1600-HP each for take-off, appeared in 1939.

The Consolited PB2Y (Model 29) Coronado, Figure 2.20, had a wing span of 115 ft (35 m) with its wing floats in their retracted position. These floats were unique in their operation. When in their retracted position, they formed the wing tips and their supporting struts fitted into pockets faired flush with the lower surface of the wing making an aerodynamically clean installation. This interesting design was shared by its more famous and more numerous twin-engine contemporary, the PB4Y (Model 24) Corsair, the bulk of available funds being allocated for PB4Y production as the world moved at a breakneck pace toward World War II.

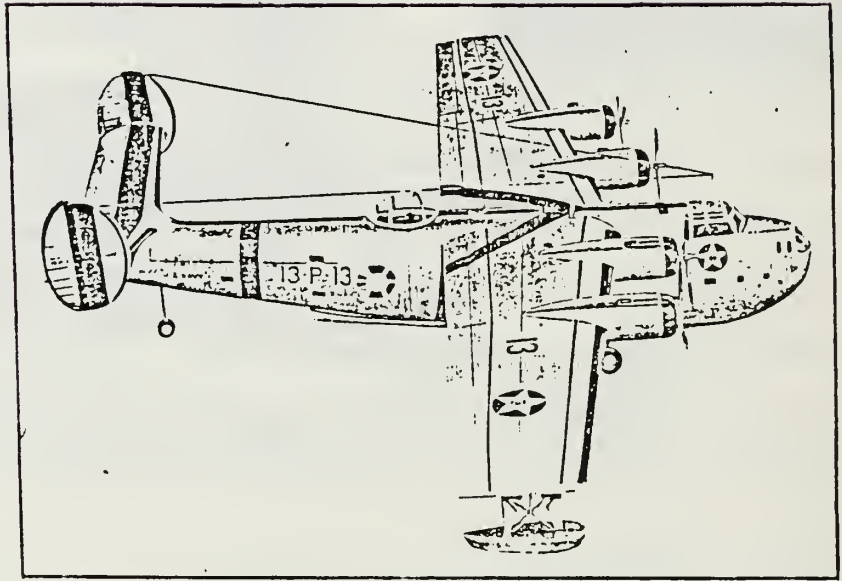

Figure 2.20 - Consolidated PB2Y-2 Coronado

B. FROM WORLD WAR II TO THE PRESENT

In the United States, in 1940, variations of the Curtiss SB2C Helldiver and the Grumman F4F (FM-2) were fitted with twin float gear. To launch these aircraft, the H-5 catapult was designed but never fully completed because the aircraft's operational concept was dropped after a limited test program.

In Germany, the Blohm and Voss BV 138A-1 was first flown in April of 1940. In this version some structural weaknesses became apparent necessitating a return to the drawing board. The resulting BV 138 B-1, with improved armament, became the configuration to which all preceding production aircraft were modified. After all this redesign and modification, the aircraft were grounded during the winter of 1940-41 due to problems with the propellers and the Junkers Jumo 205C Diesel engines. For those not familiar with aircraft powerplants, it is worth relating that these engines were technically unique. They had six cylinders and 12 pistons. Two crankshafts at the upper and lower ends of the engine were geared to a common propeller shaft and two pistons converged at the centre of the cylinder. The Jumo 205s were the most successful and the most widely produced of the very few diesel aircraft engine designs.

In 1940 a new approach to flying boat design was launched by Blackburn Aircraft Ltd. combining features of flying boats and single-float hydroplanes on a large scale. The B.20, Figure 2.21, was a design in which the propellers were kept clear of the water while mounted on engines that were installed in the leading edge of the wing, providing a better aerodynamic combination. To accomplish this, the lower portion of the hull was constructed of a self-contained central float or hull. In flight, this float was tucked up against the fuselage producing a neat, low air resistance airframe. During take-off, landing and while at rest, this large central float was lowered simultaneously

with the retractable wing-tip floats. This unusual design feature also placed the wing at its most advantageous angle of incidence for take-off and landings.

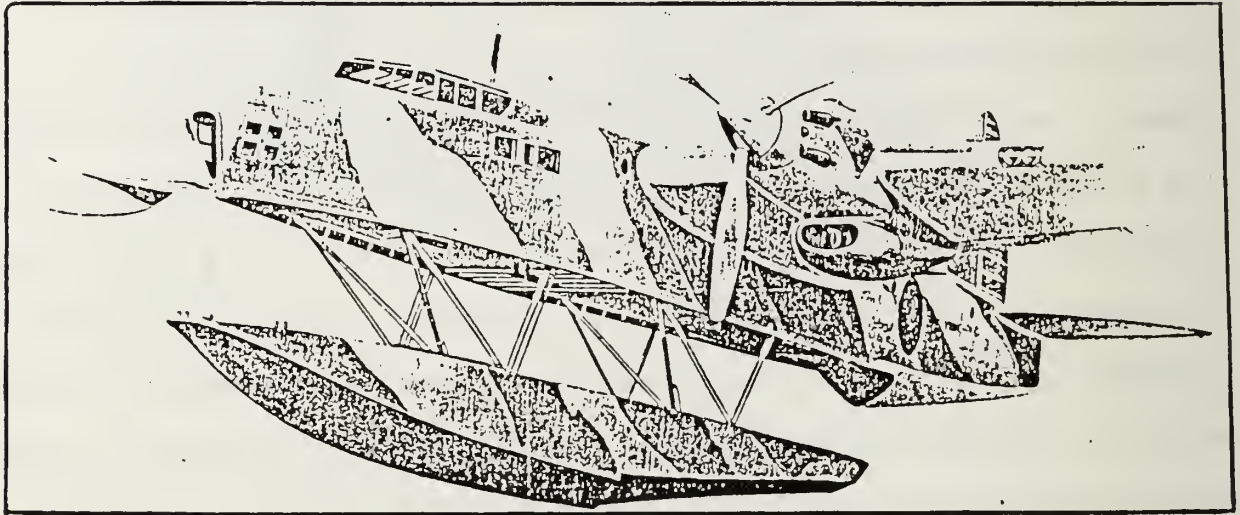

Figure 2.21 - Blackburn B.20

With World War II underway a number of aircraft in development, which were anticipating such an eventuality, began to emerge. Among these was the gigantic Blohm und Voss BV 222 Wiking which made its first flight on 7 September, 1940, and was used as Luftwaffe transports instead of service with Lufthansa, for whom the design was begun.

The Northrop N-3PB, Figure 2.22, despite its attractive lines, saw little service in World War II, operated by the RAF from Iceland in an anti-submarine role in 1941-42 before being replaced by PBV-1s.

An aircraft which caused more than its fair share of attention was the Yokosuka E14Y1 Glen, Figure 2.23. This very ordinary design was also intended for submarine scouting. Its claim to fame was the widespread consternation and general nervousness created along the western coast of the United States. Shortly after the Pearl Harbor attack of 7 December, 1941, a single Glen was launched from a Japanese submarine off the coast.

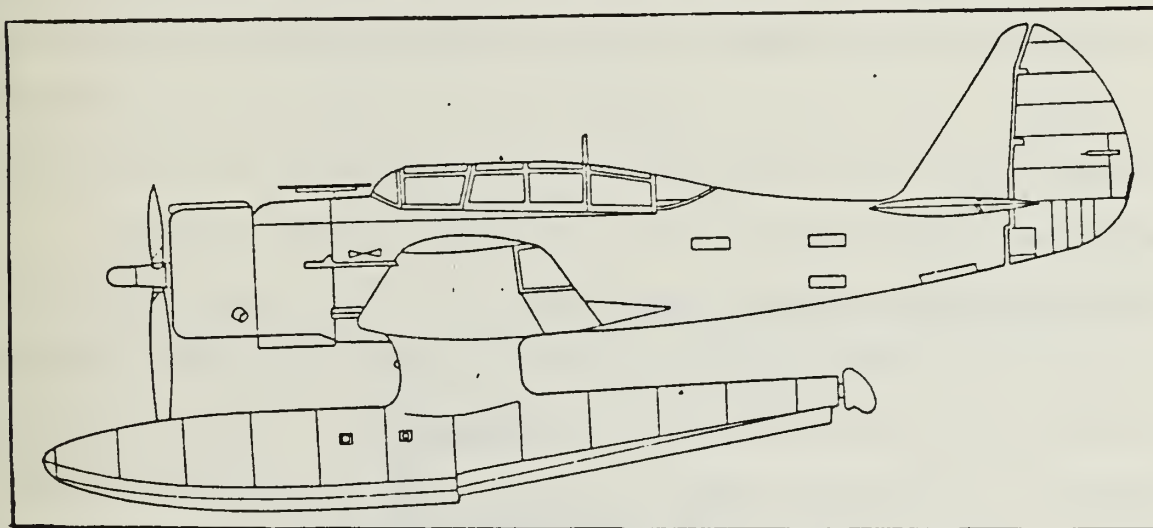

Figure 2.22 - Northrop N-3PB

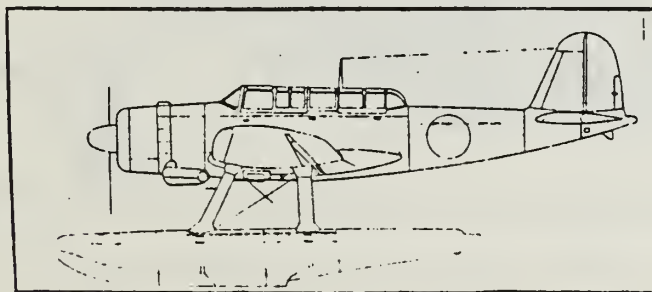

Figure 2.23 - Yokosuka E14Y

In the United States, one of the peculiarities of the US Coast Guard procurement through the years is that their aircraft have been ordered by the US Navy, therefore, many of the aircraft ordered by the Navy were actually operated by the Coast Guard. In December 1941, the Coast Guard was absorbed into the Navy for the duration of World War II and one aircraft, the Dolphin, was assigned to submarine security patrol along the Atlantic coast of the United States.

The Grumman J2F-2 Duck was adopted for the pacific operations in 1942 and was armed in its first version with two machine-guns and racks for light bombs

Another aircraft under development prior to the war was the Martin Model 170 XPB2M-1 Mars, later redesignated JRM-1, Figure 2.24. As a pre-war design, provisions for combat service based on experience gained as the war progressed, were not readily incorporated in the PB2M-1 since conversion of the Mars to full combat capability would have been prohibitively expensive and so this aircraft was converted to a transport version. On its first flight in December 1943, the Mars carried a 13 000-lb (5 900-Kg) load from Patuxent Naval Air Station, Maryland, to Natal, Brazil, a distance of 4375 miles (7040 Km) non-stop.

On the Japanese side, the Nakajima A6M2-N (RUFE) was the floatplane version of the Zero-Sen carrier fighter and had slightly different tail surfaces to accommodate an enlarged rudder. It developed a maximum speed of 434.5 Km/h and a maximum range of 1783 Km, powered by a 1000-Hp Nakajima Sakae 12/14-cylinder radial air cooled engine, Figure 2.25.

In 1942, Howard Hughes and Henry Kaiser, a prominent shipbuilder, agreed to build three giant experimental flying boats for the U.S. Government. Because of concern over shortages in strategic materials the construction was to be entirely of wood, no easy task in view of the fact that these aircraft

had a wing span of 320 feet and had to be able to carry up to 700 troops. In 1944 the Government cancelled this project, but suggested to complete a mock-up in order to determine the feasibility of an all-metal flying boat of similar type. Howard Hughes rejected this suggestion and decided to personally fund one aircraft, reportedly spending 22 million dollars. This aircraft, the H-4 Hercules, had an empty weight of 400,000 lb and was powered by eight 3000 HP Pratt & Whitney Wasp Major engines. Howard Hughes flew the Hercules on 1 November 1947 over a distance of one mile and then ordered it to be mothballed. The Hercules remains today the largest aircraft ever flown.

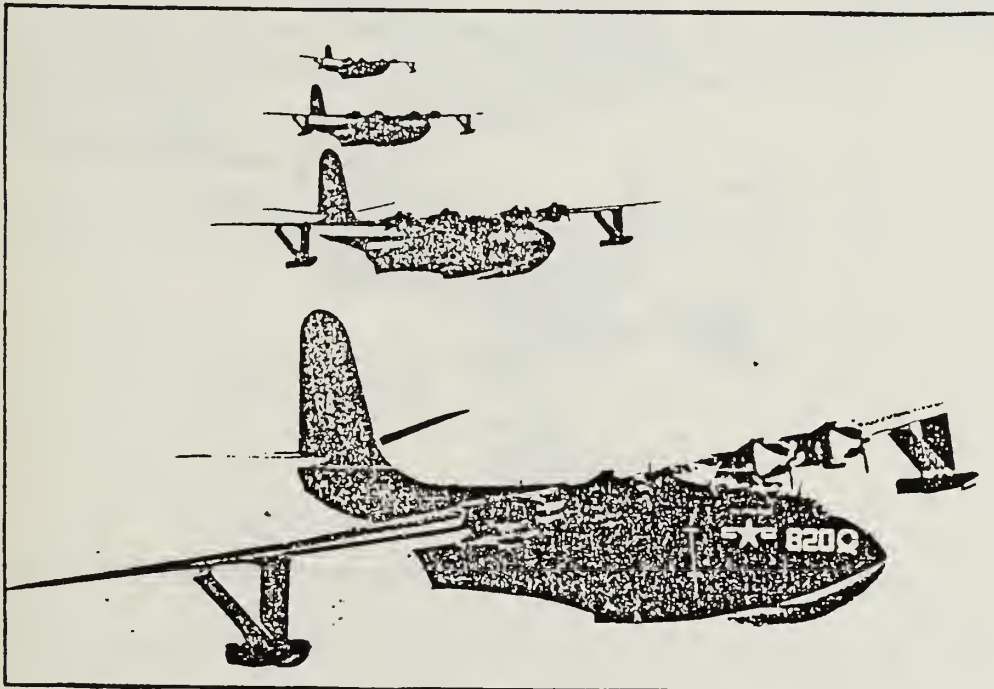

Figure 2.24 - US Navy Martin Mars

The Supermarine type 309 Sea Otter, Figure 2.26, was designed as a replacement for the war-weary Walrus which had been carrying the load and was badly in need of improvement. The Otter became available in 1944 and was designed to operate from carriers and served primarily as an air-sea rescue aircraft but was also fitted to carry bombs or depth charges on universal racks under the lower wings.

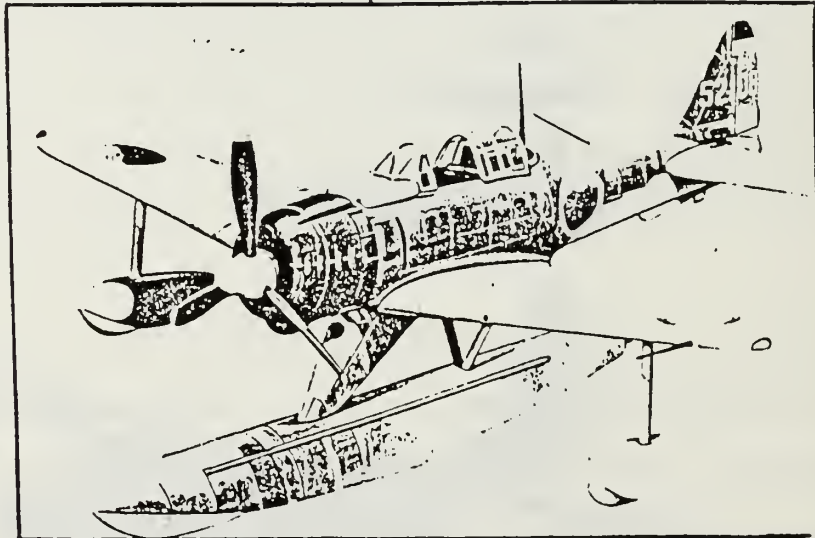

Figure 2.25 - Nakajima A6M2-N (RUFÉ)

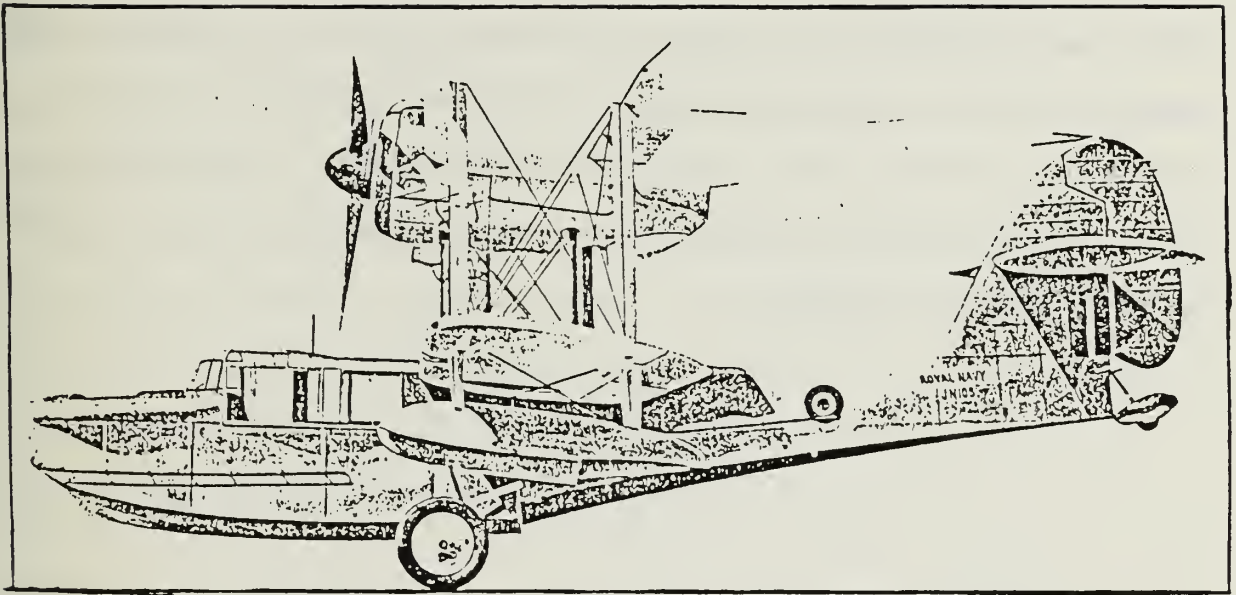

Figure 2.26 - Supermarine Sea Otter

The Japanese Aichi M6A1 Seiran, Figure 2.27, a submarine-launched float-plane, which required that the folded wings and tail surfaces were spread and locked in flying position, was able to fly in about one minute and was built with the primary mission of destroying the Panama Canal, launched from a I-400 submarine in 1945. Plans to use the Seiran were shelved, fortunately, because the hostilities were ended before the attack could be undertaken.

During World War II, the Germans adapted the composite aircraft concept to military purposes. In early 1943 the German Air Ministry asked for a means of launching an aircraft loaded with explosives against a vital target. The Junkers Aircraft Company proposed to combine an unmanned JV-88 bomber with a manned Bf-109 that would guide the unmanned aircraft to its target. The prototype combination was completed in July 1943 and the ensuing flight tests proved the practicality of the concept. The unmanned aircraft could carry a 3500 kg warhead capable of penetrating 60 feet of concrete. Although these composite aircraft were successfully employed against bridges and other targets on the eastern front, the lack of guidance after release from the carrier aircraft was a serious problems. Later versions used the Focke-Wulf FW-190 as carrier aircraft.

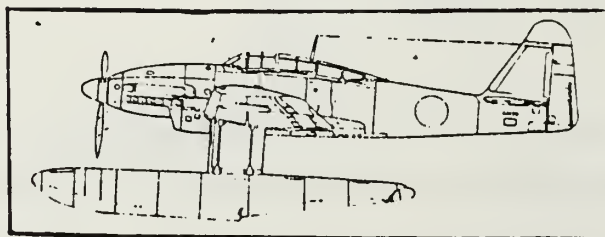

Figure 2.27 - Aichi M6A1 Seiran

Anticipating the end of the war, Short Brothers set out to produce a completely civilian transport aircraft, the S.25 Sandringham, which appeared in 1945. All armament positions were neatly faired, producing a fine looking aircraft which would be ready at the end of the war. At the same time developments were underway on the Short Seaford, which resulted in the Short S.45 Sonolent, Figure 2.28, a more powerful and much heavier replacement of the Sunderland, which would gross at 75,000 lb (34 000 Kg), instead of the 65,000 lb (29 500 Kg) of the original war model. This seaplane proved to be very popular with passengers flying the Empire routes to South Africa until November 1950.

The history of seaplanes shows that in May 1946 the Marshall Mars established an unofficial record carrying 301 passengers and a crew of seven from Alameda Naval Air Station to San Diego Naval Air Station. The final Mars, designed JRM-2, was delivered in late 1947 and its operating gross weight was 165,000 lb (74,850 Kg).

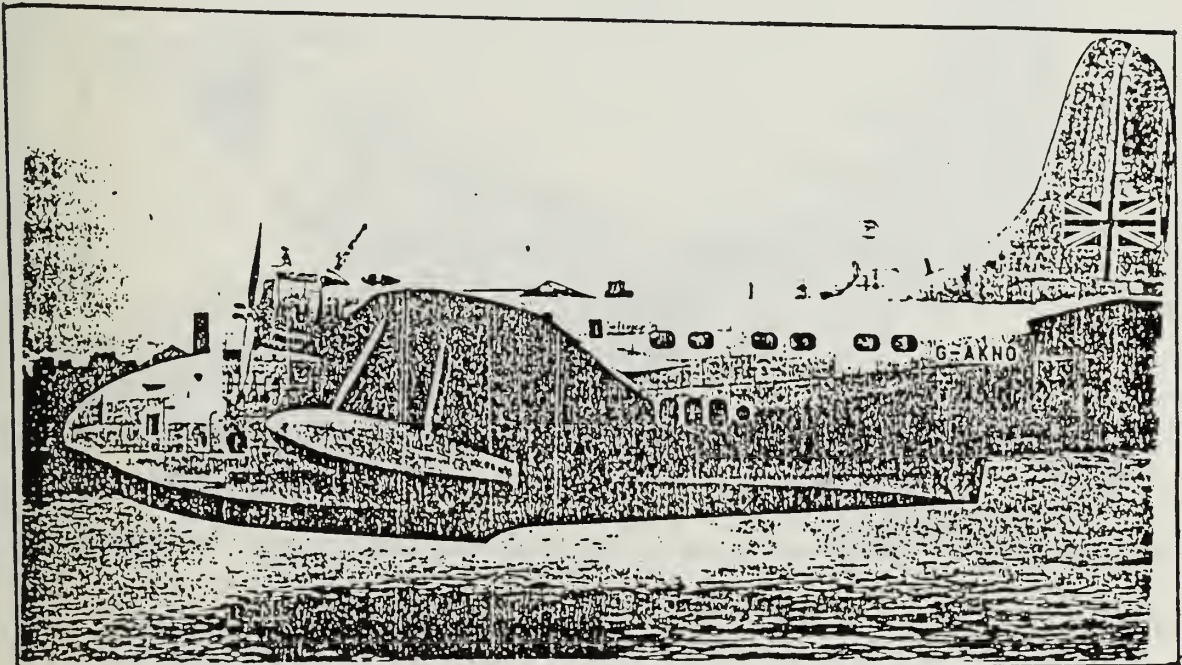

Figure 2.28 - A Boac Short Sonolent Landing on the Thames

The first jet-powered flying boat, the Saunders-Roe SR/A1, flew on 15 July 1947, Figure 2.29.

Still in 1947, the Grumman Albatros SA-16, Figure 2.30, first flew and was intended to be a utility amphibian, carrying a crew of five or six and 22 passengers. It was exported to 12 nations through the MAP program and Norway and Spain operated ASW versions.

The first flight of the Martin Marlin P-5, Figure 2.31, another post-war design, occurred in May 1948. Its distinctive "nose" housed an APS-80 radar and there were twin 20-mm cannons in the sting position. Its normal crew was eight and it could carry eight 1 000 lb (450 Kg) and two 2 000 lb (910 Kg) bombs.

To mark the 30th anniversary of British Commercial Air Transport, the BOAC Short Sonolent landed on the Thames, as one can see in Figure 2.28.

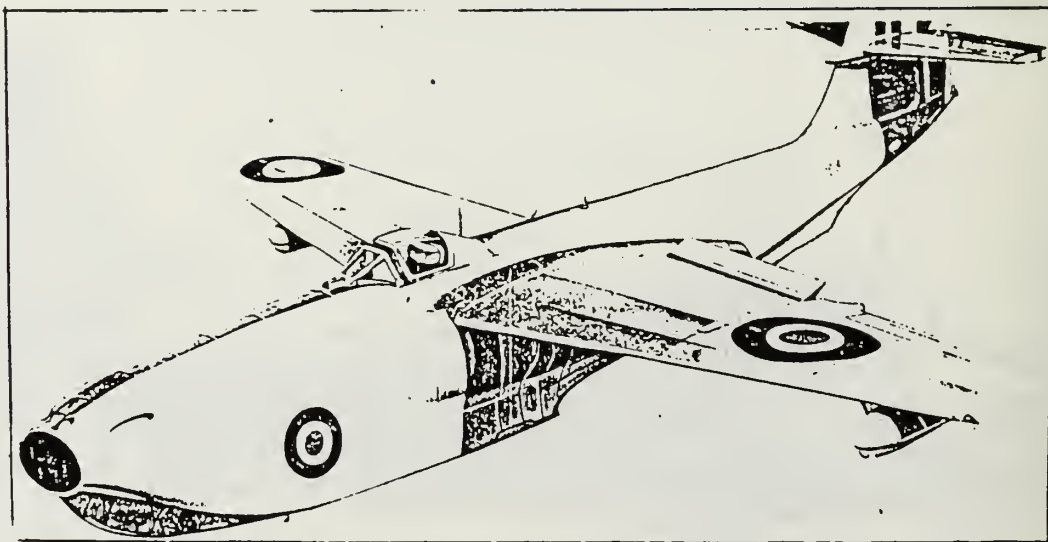

Figure 2.29 - Saunders-ROE SR/A1

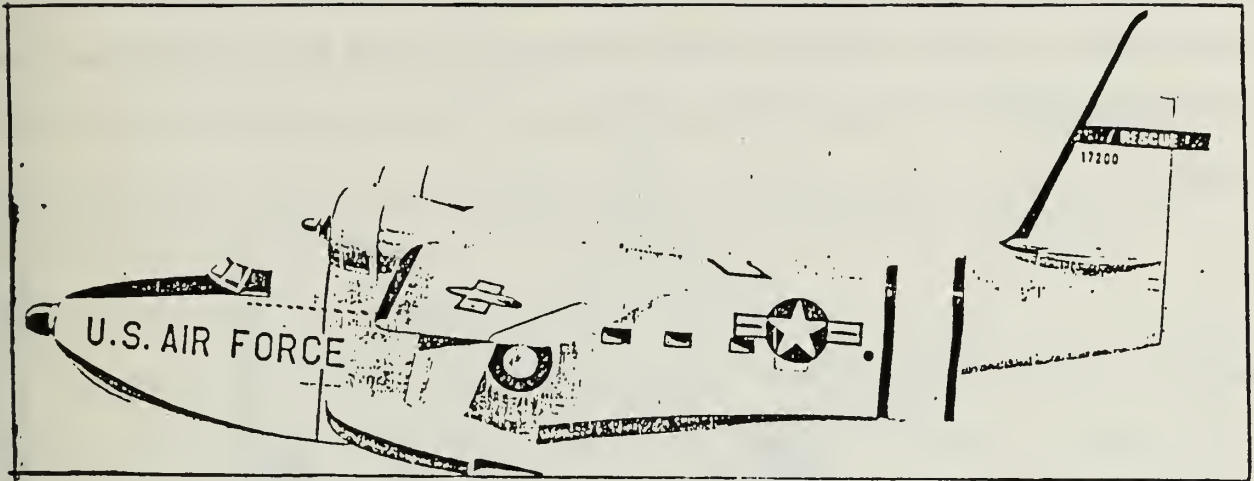

Figure 2.30 - Grumman Albatross - SA-16

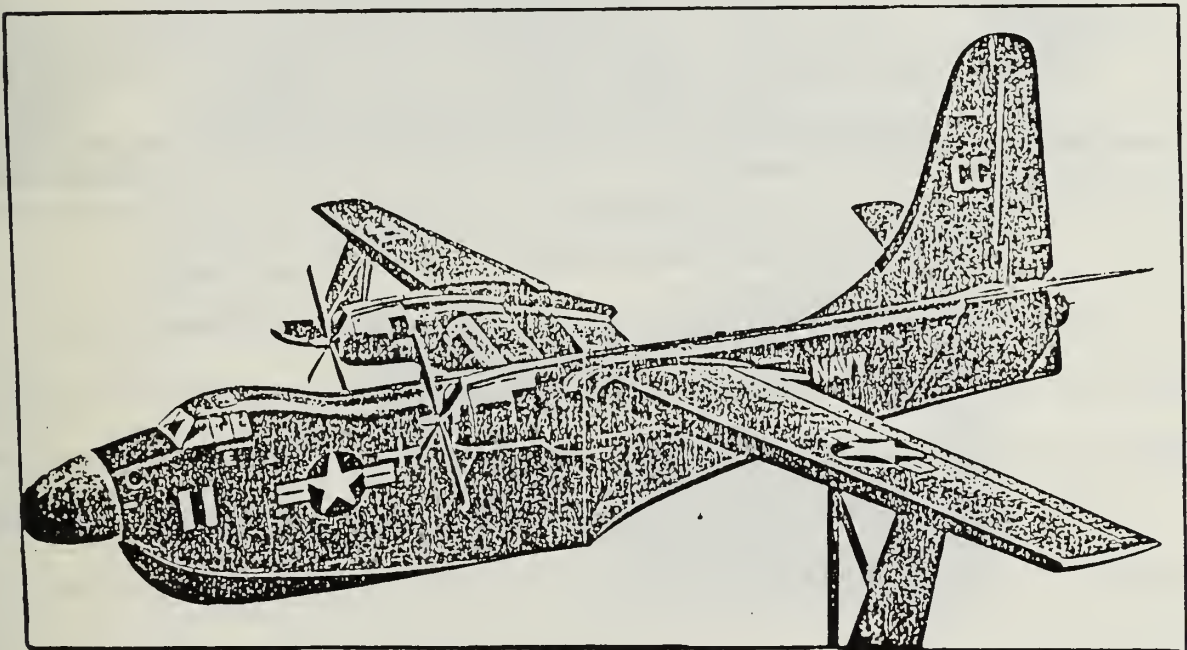

Figure 2.31 - Martin Marlin P-5

The Tradewind was a ruggedly handsome high-wing monoplane powered by Allison XT-40-A-4 engines which were themselves an interesting development. The Tradewind was the only turbo-prop-powered flying boat to be accepted by the US Navy. It was designed to serve as a patrol boat but was converted to a transport and the first of these aircraft was flown in April, 1950, Figure 2.32.

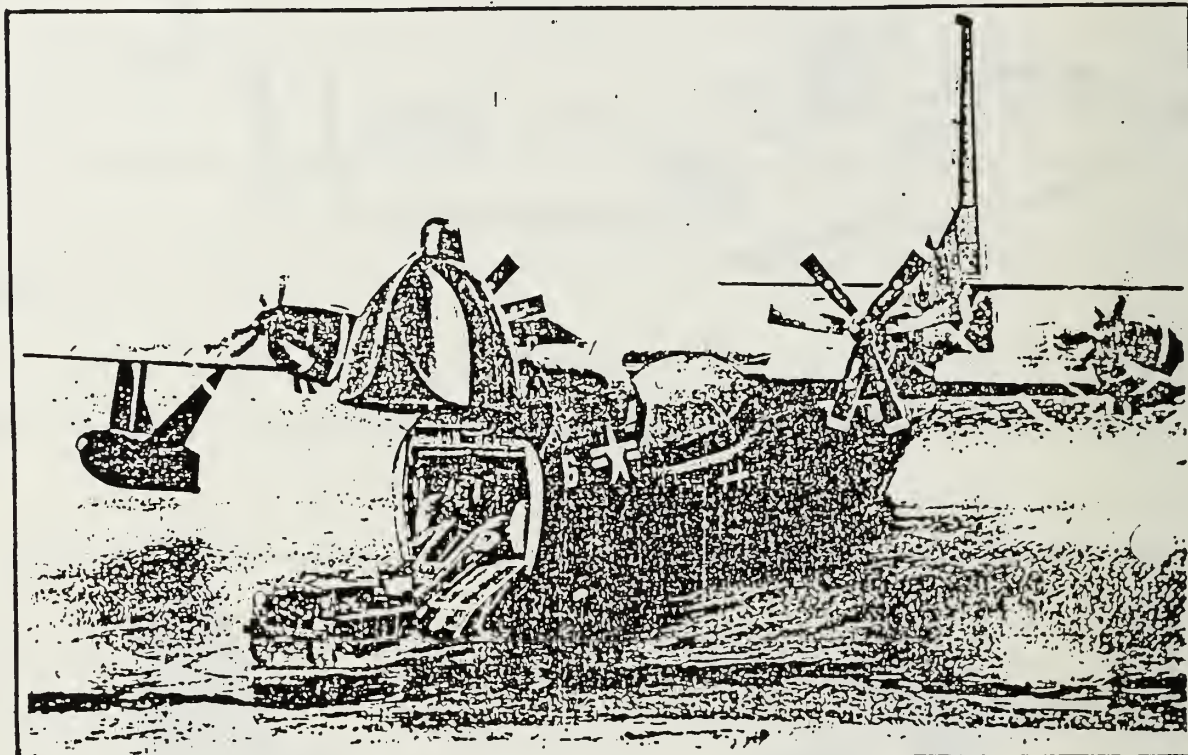

Figure 2.32 - Convair Tradewind

In April, 1951, the Seamaster history began when the Chief of Naval Operations issued an operational requirement for a high-performance all-jet seaplane that would live on the water, and be supported primarily by tenders.

In 1952, Martin was awarded a production contract for two prototypes known as Model 275. They would be modern in almost every way if produced today, several years after their untimely destruction during tests. They had a small crew of four and a gross take-off weight of 160 000 lb (72 575 Kg), the same as the Tradewind.

In 1953, on April 9, the Sea Dart, an interesting waterborne fighter concept, designed by Convair, the SF2Y-1, first flew, Figure 2.33. It incorporated such niceties as a delta wing, which, because of its location, also provided lateral stability when on the water, there being no requirement for wing-tip floats. The test program verified the technical possibilities of this aircraft configuration and succeeded in pushing a flying boat beyond Mach 1, on August 3, 1954, before disaster struck in the form of a mid-air disintegration of one of the aircraft.

The Martin P6M Seamaster prototype, first flown on 14 July, 1955, embodied all the design features developed during and after World War II, Figure 2.34.

On December 7, 1955, after completing 37 hours of flight time the Number One XP6M-1 prototype was lost over the mouth of the Potomac River west of Point Lookout during a test flight.

Three crew members and a naval officer lost their lives, and from December 8, 1955 to March 2, 1956 full-fledged salvage operations were conducted in the Potomac River.

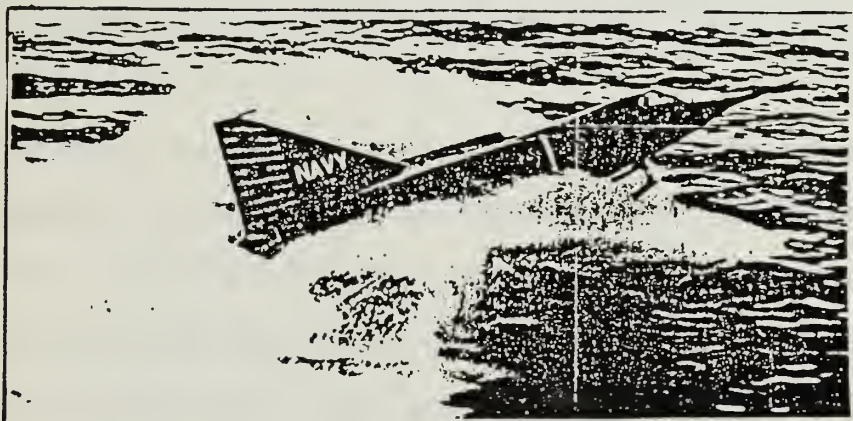

Figure 2.33 - Convair XY2Y-1 Sea Dart

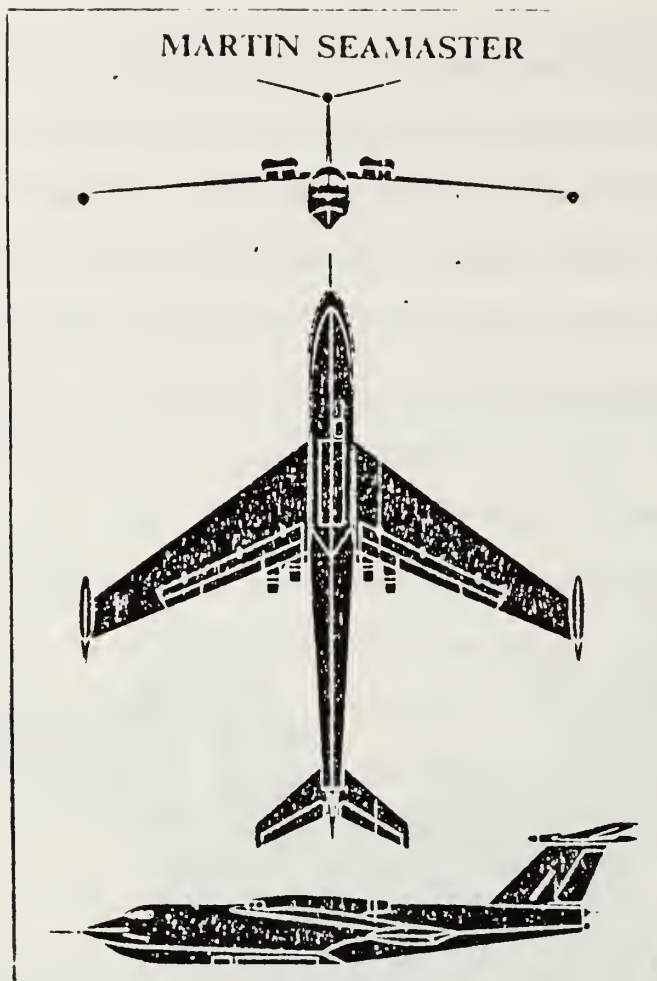

Figure 2.34 - Martin Seamaster

The first flight of the HU-16A, an improved version of the SA-16A, the amphibian aircraft used by USAF in salvage missions, occurred on 16 January 1956.

On January 25, 1957 the improved HU-16A was changed to HU-16B, and first flown. Sixteen of this special model were sent to Norway to perform anti-submarine warfare operations.

In the autumn of 1959, the Seamaster project and the XP6M-1 and -2 were terminated, and in 1960, the last P5M designed as a replacement of the P4M, was produced.

The Beriev BE-12 TCHAIKA (Seagull), NATO code name MAIL was first seen in the Tushino air display, in 1961, Figure 2.35.

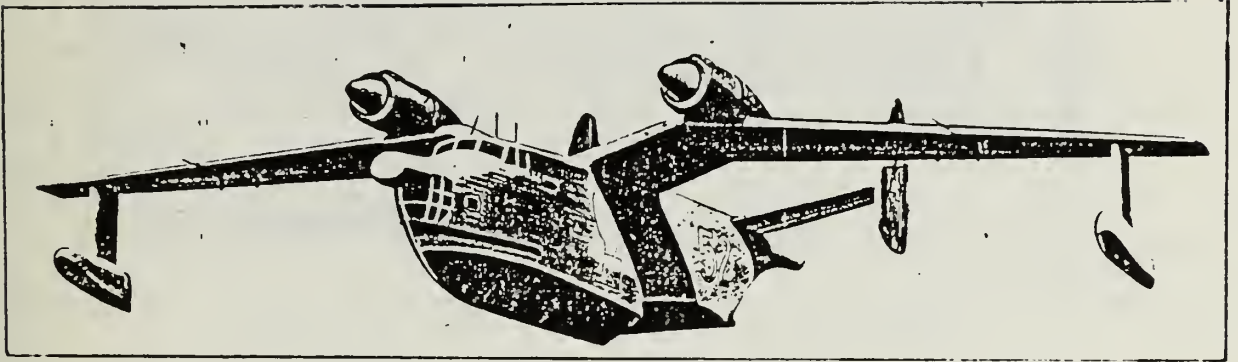

Figure 2.35 - Beriev BE - 12 Tchaika

The Mail gross take-off weight is about twice the weight of the Grumman Albatros but needs more than twice its horse-power.

In 1962, the designation amphibious was suppressed from the Grumman Albatros SA-16, and at the end of 1964, it changed its designation to HU, like HU-16A or HU-16B.

In 1964, the UF-XS (Experimental Aircraft), using the airframe of the Albatros, flew in Japan for the first time, Figure 2.36.

This model was a 3/4 scale model of the PS-1, the anti-submarine warfare Japanese flying boat, Figure 2.37.

The Short Sandringham, a civilian version of the Sunderland V, that first flew in 1945, and the P5M, serving with the US Coast Guard and the US Navy, remained in service until 1966, Figure 2.38.

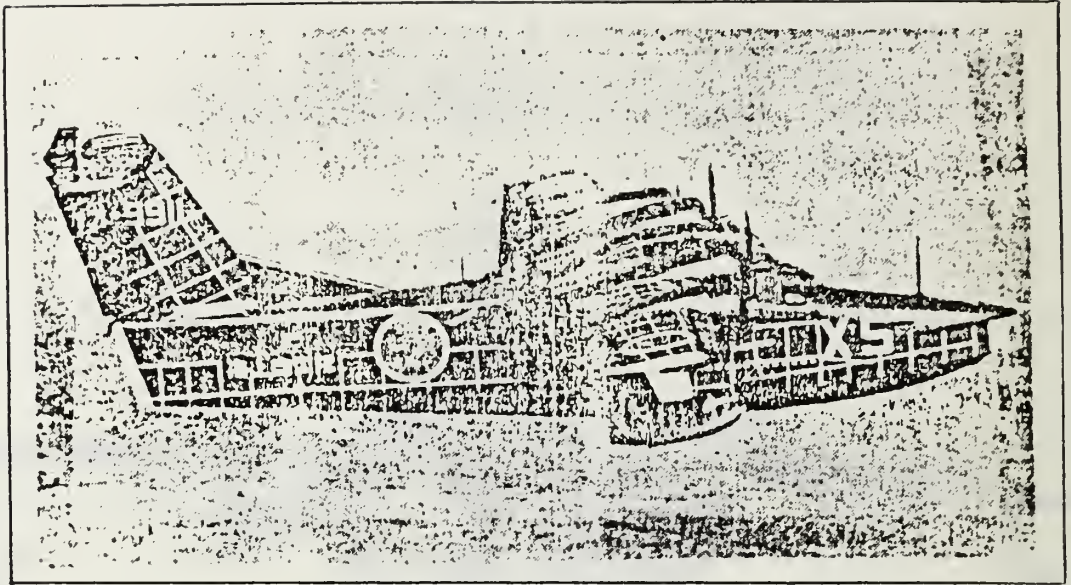

Figure 2.36 - UF-XS (Experimental Aircraft)

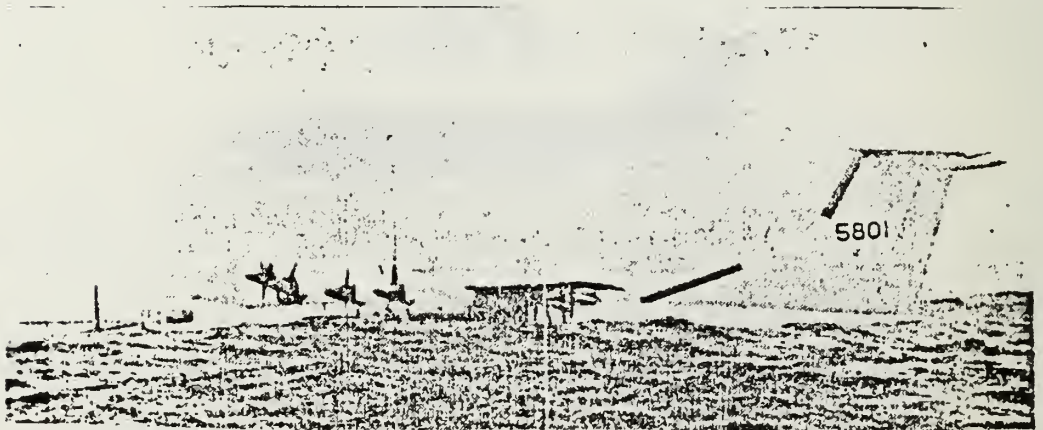

Figure 2.37 - PS-1 Japanese Anti-Submarine Warfare Aircraft



Figure 2.38 - Short Sandringham

In 1967 the first flight of the PS-1, Figure 2.39, took place in Japan and by 1969 the first Canadian CL-215 became operational which was designed for patrolling the vast forest areas of Canada and, when required, to fight forest fires. In addition to its proven ability as a "water bomber", the CL-215 can carry up to 19 passengers, primarily fire fighters, and fire extinguishing equipment.

Replacing the beaching gear of the PS-1 with a landing gear converted it into an amphibian aircraft and with necessary internal equipments for airsea rescue, it became the "US-1".

Its first flight took place in 1974 and it is able to perform short take-off missions from land airports and to make slow water landings, carrying a twelve member crew, including medics and rescueman.

In February 1975 the PS-1 (Patrol Sea-1) entered service for the Japanese Maritime Self-Defense Force, and by July, 1976, an Air Rescue Squadron was inaugurated at Iwakuni Naval Air Station. By September 1981, approximately 120 rescue missions had already been accomplished.

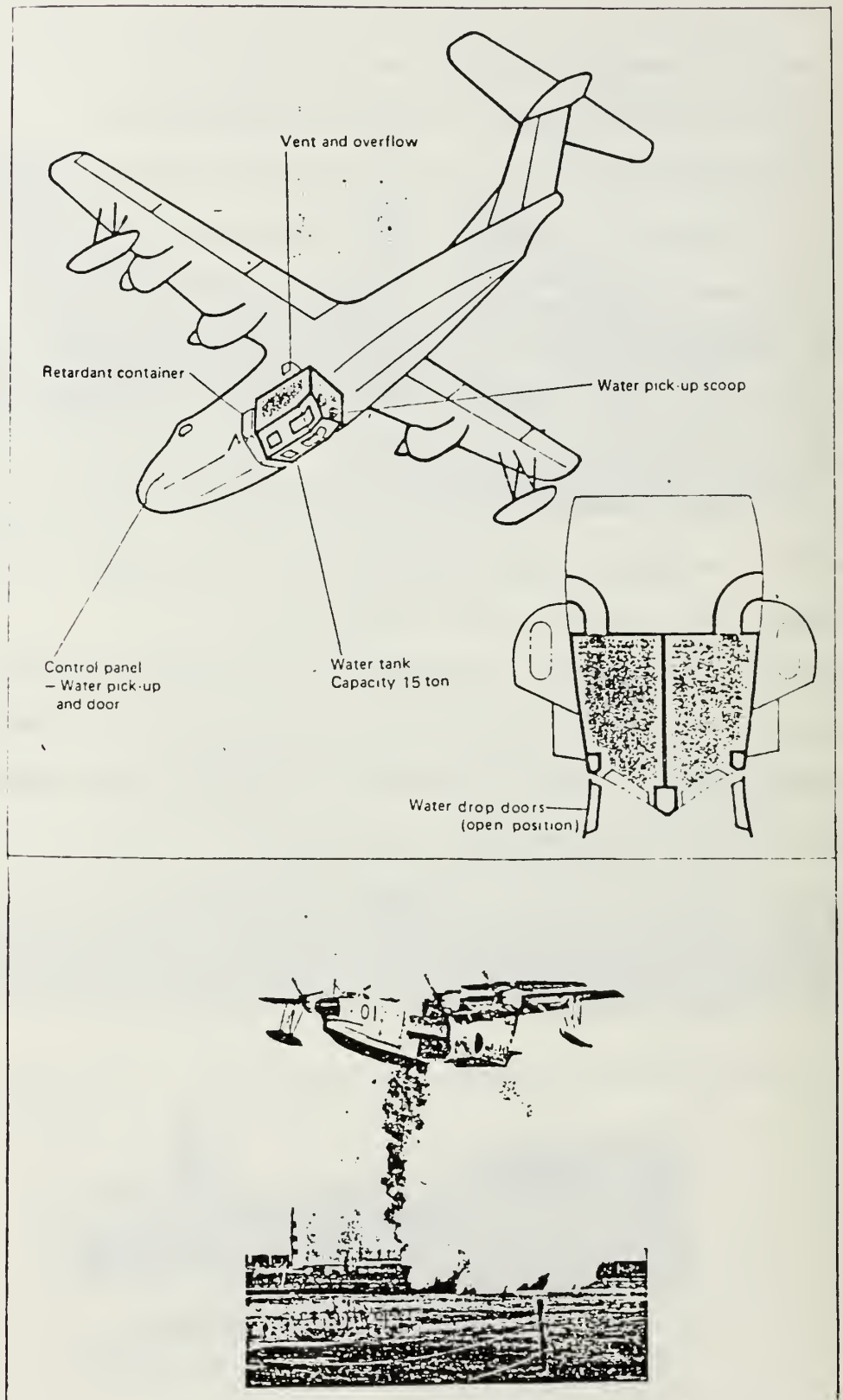

Figure 2.39 - PS-1A - The Water Bomber Mission

C. FLYING AIRCRAFT CARRIERS

As noted in "History of Aviation", Reference 12, the conflict between the demand for higher speeds and improved maneuverability, requiring low wing loadings, and the need for greater range and bigger armament loads, requiring high wing loadings, has led very early to the idea to use "mother aircraft" to carry fighters aloft.

By the end of World War I the three major airship powers, Britain, Germany and the United States, had experimented with this idea. The Germans launched an Albatross D.III from the L35 rigid airship, the British launched a Camel from their R23 rigid airship, and the Americans used a Curtiss JN-4 from a Navy C-1 blimp.

In 1925 the British continued work on this concept by incorporating a trapeze on the R33 rigid airship for aircraft launch and retrieval in flight. Unfortunately, this program was conducted in a rather desultory manner and finally abandoned in December 1926.

In 1929 the U.S. Navy began trapeze flying from the Los Angeles airship, built by the Zeppelin company as part of Germany's war reparations. This was followed by trials from the Akron rigid airship in mid-1932, using Curtiss XF9-C1 Sparrowhawk biplanes. Many problems were encountered. The major concern was the possibility of mechanical failure of the trapeze, making it impossible for aircraft already launched to return to the airship. The need for a second trapeze was recognized, but the Navy's budget problems prevented its installation before the Akron's crash in April 1933. The flights were continued off the Macon, again with only one trapeze, until the Macon's loss in February 1935.

In 1931, this same idea started to be pursued in Russia where Igor Sikorsky had already given the country a commanding lead in the construction of big bomber airplanes. In November 1935, a TB-3 bomber was used to carry two I-16 monoplanes under the wings, two airplanes above the wings and a trapeze was attached to allow a fifth fighter to hook on under the fuselage after the combination was airborne. The full power of the four fighters as well as of the bomber was needed to achieve take-off. In the following years a TB-3 and two I-16 aircraft, modified to carry two 550 lb bombs in a dive bombing role, reached operational status and were, in fact, used in World War II to attack a bridge over the Danube in August 1941.

In 1935, Imperial Airways, with the support of the British Air Ministry, asked Short Brothers to design a pair of seaplanes for the purpose of providing sufficient range to cross the North Atlantic. The idea was to produce a mother aircraft which would take off with a smaller airplane on its back, to be launched when cruising height and speed were reached. This composite aircraft was never put in regular service. However, in October 1938, it set a new seaplane record by flying a 6000 mile distance from Scotland to South Africa.

During World War II the USAAF evolved the requirement to provide built-in defensive fighter protection for the global bombers then beginning to be proposed. The pilot would be carried in the mother bomber prior to launch of the fighter aircraft which had to be small enough to fit inside the bomber. In response to this requirement, McDonnell Aircraft Company designed the XF-85 Goblin, a small jet-powered fighter with upward folding wings for storage in the bomb bay. Two prototypes were built and trials were conducted with a

trapeze mounted on a Boeing B-29. Considerable difficulties were experienced and the project was finally cancelled in 1949. However, the USAAF continued to advocate fighter escort for the B-36 reconnaissance version of the basic B-36 aircraft. Therefore, new trials were made with Republic RF-84F Thunderflash fighters in May 1953 which turned out to be successful. About a dozen B-36 aircraft were converted as carriers and a squadron of RF-84F fighters was modified for skyhook operations. However, at that time the emphasis was changed toward extending the range of the fighter aircraft and little operational flying experience was accumulated with this concept before abandoning it in the late 1950's.

Finally, it should be recalled that the "piggy-back" concept was successfully demonstrated in recent years when the space shuttle was successfully launched from a Boeing 747 aircraft for landing tests prior to launch of the first shuttle flights.

III. SEAPLANES AS CARRIER OF FIGHTER/ATTACK AIRCRAFT

A. POSSIBLE SCENARIOS TO USE SEAPLANE AIRCRAFT CARRIERS INSTEAD OF SHIP AIRCRAFT CARRIERS

To better visualize a possible scenario to use seaplane aircraft carriers instead of a ship aircraft carrier, let us look at recent war episodes, the Falklands war and the attack on Libya, as examples.

1. The Falklands War

After the Falklands invasion by the Argentinean forces on April 2, 1982, the British government started Operation "Corporate", to recover the islands by military force. The British forces were confronted with the following facts:

- o The Falklands are 8000 miles from the United Kingdom and 3500 miles from Ascension Island, but only 400 miles from the Argentinean territory.
- o The Wideawake Base, on Ascension Island, is the nearest British operational base from the Falklands.
- o In order to send an aircraft carrier to the Falklands for the purpose of launching an aircraft attack against Port Stanley, the British would have had to wait at least two weeks, thus giving the enemy forces ample time for counter-measures.

For this reason, specialized training was started by the British pilots in order to be able to refuel the Vulcan and the Victor aircraft in flight. The goal of this so-called "Black Buck" Operation, Figure 3.2, was to destroy the Port Stanley runway, in order to prevent the take-off of the Argentinean combat aircraft.

Two Vulcans and eleven Victors were prepared for inflight refueling. The two Vulcans were loaded with 21 454-kg bombs each for the purpose of dropping these bombs in 46 m intervals, making a 30 degree angle with the runway axis.

At 10:50 p.m., Ascension island time and 7:50 p.m. Port Stanley time, on April 30, 1982 the two Vulcans took-off from Wideawake Base. One aircraft soon encountered problems with the refueling hose forcing its return to the base. The second aircraft proceeded with the mission piloted by Captain Martin Withers and his crew.

At the same time, ten of the eleven Victor refueling aircraft took-off and after 45 minutes, about 1 350 km from Ascension Island made the first fuel transfer in flight. Four Victors, that we will call #1, #3, #5 and #7 transferred all their available fuel to the other four Victors, that we will call #2, #4, #6 and #8. The #1, #3, #5 and #7 returned to the base. At the same time, another Victor, #10, refueled the Vulcan but continued flying with the group.

During these refuelings, a problem was observed that almost caused the cancellation of the operation: as the Victors and the Vulcan were obliged to fly together, neither the speed nor the altitude were appropriate for both kind of aircraft.

The second fuel transfer occurred about 1 850 km from Ascension Island, two and a half hours after take-off, and then, Victor #9 transferred all available fuel to the Vulcan, returning to the base. At the same time, two Victors, #2 and #10, transferred their available fuel to Victors #4 and #8, respectively. The #2 and #10 returned to the base.

The third refueling process occurred 3 060 km from take-off, after four hours of flight when Victor #8 refueled the Vulcan and proceeded with the group, while Victor #4 completely refueled Victor #6 and returned to the base.

After the third refueling was completed the first refueling group encountered a nightmare because they returned with too little fuel, and had to

land in unfavorable wind conditions. If each landing aircraft had followed the normal landing and taxiing procedure, the third and fourth aircraft would have run out of fuel. Therefore, the Victors were landing and stopping at the end of the runway.

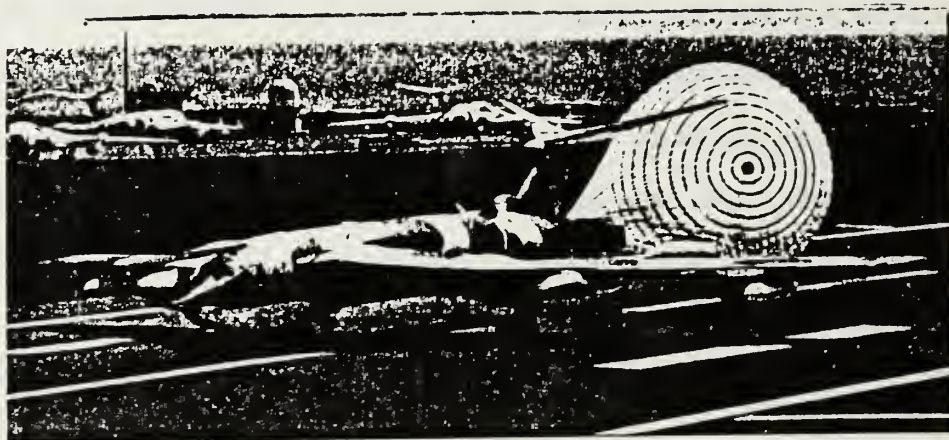

Figure 3.1 - A Victor Landing in Wideawake

The fourth refueling process occurred 4 350 km from take-off, five and a half hours after take-off with Victor #8 refueling the Vulcan and Victor #6, flying at 9 450m, encountering a strong storm. Victor #8 returned to the base.

The fifth refueling from Victor #6 to the Vulcan occurred at 645 km north-west of Falklands, a little bit before dawn.

At 470 km from the target area Captain Martin Withers, the Vulcan's Commander, started to descend to keep his machine out of any radar signals from the Falklands and stabilized at 600 m of altitude. At 75 km from Port Stanley, Withers quickly raised the Vulcan to 3050 m in order to attack the target, as previously planned.

An inverse operation, with two Victors supporting the return, was performed. These in-flight refueling operations are shown in the figure below.

A second Black Buck Operation was performed on May 4. Another mission planned for May 13 was cancelled due to weather conditions.

Other Black Buck Operations were performed during the war in order to destroy radars on the continental coast, using Shrike missiles.

In one of these Black Buck Operations, the Vulcan refueling intake system malfunctioned forcing the crew to perform an emergency landing in Rio de Janeiro under very trying circumstances.

If a seaplane carrier aircraft had been available, air attacks on the Falklands could have been carried out without extensive preparation and with less operational effort.

A government could take the engagement decision while the seaplane is flying to the war theater. If the diplomatic negotiations fail the seaplanes are able to launch an attack within a very short period of time with very high effectiveness, deciding very shortly the outcome of the war.

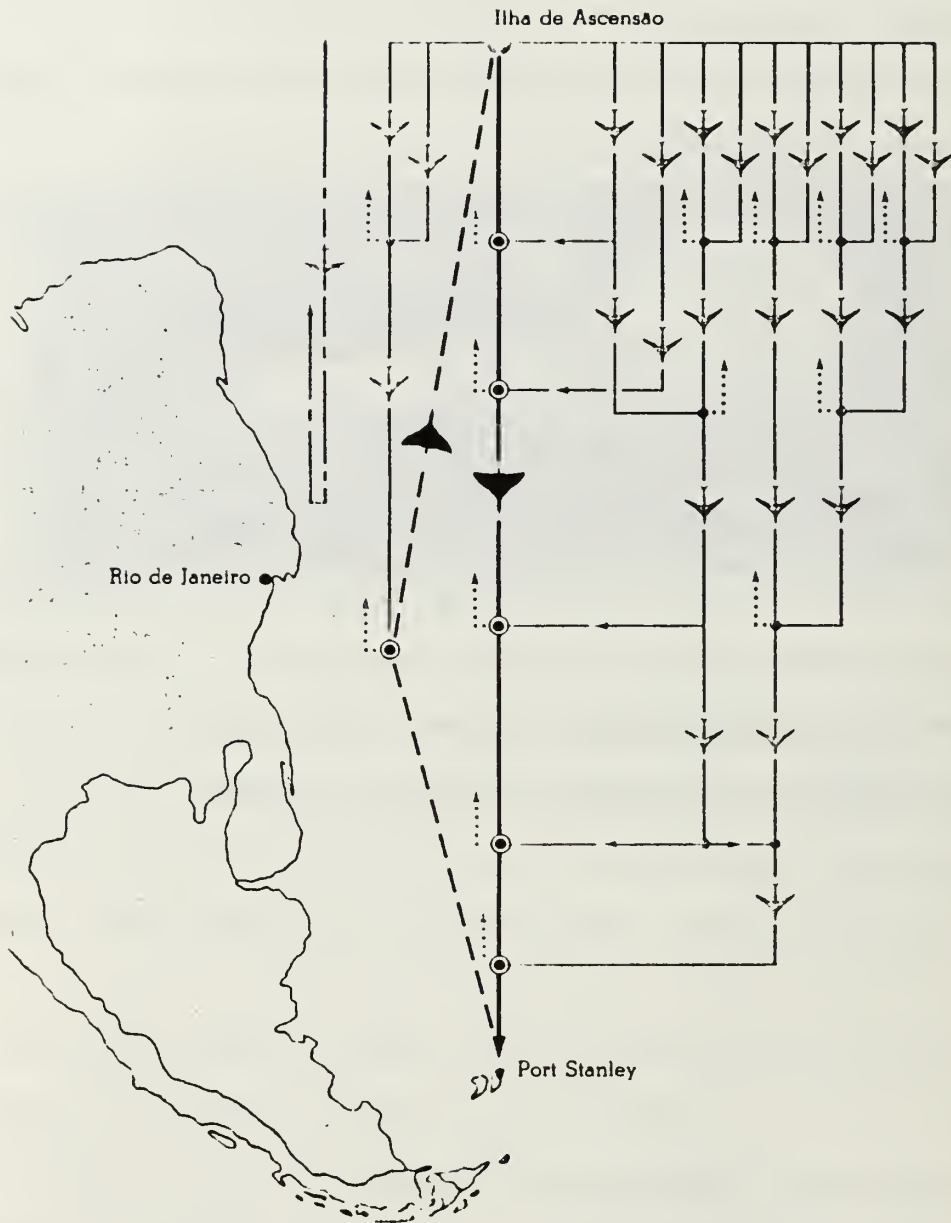

Figure 3.2 - The Black Buck Operation



Figure 3.3 - Shrike Missile

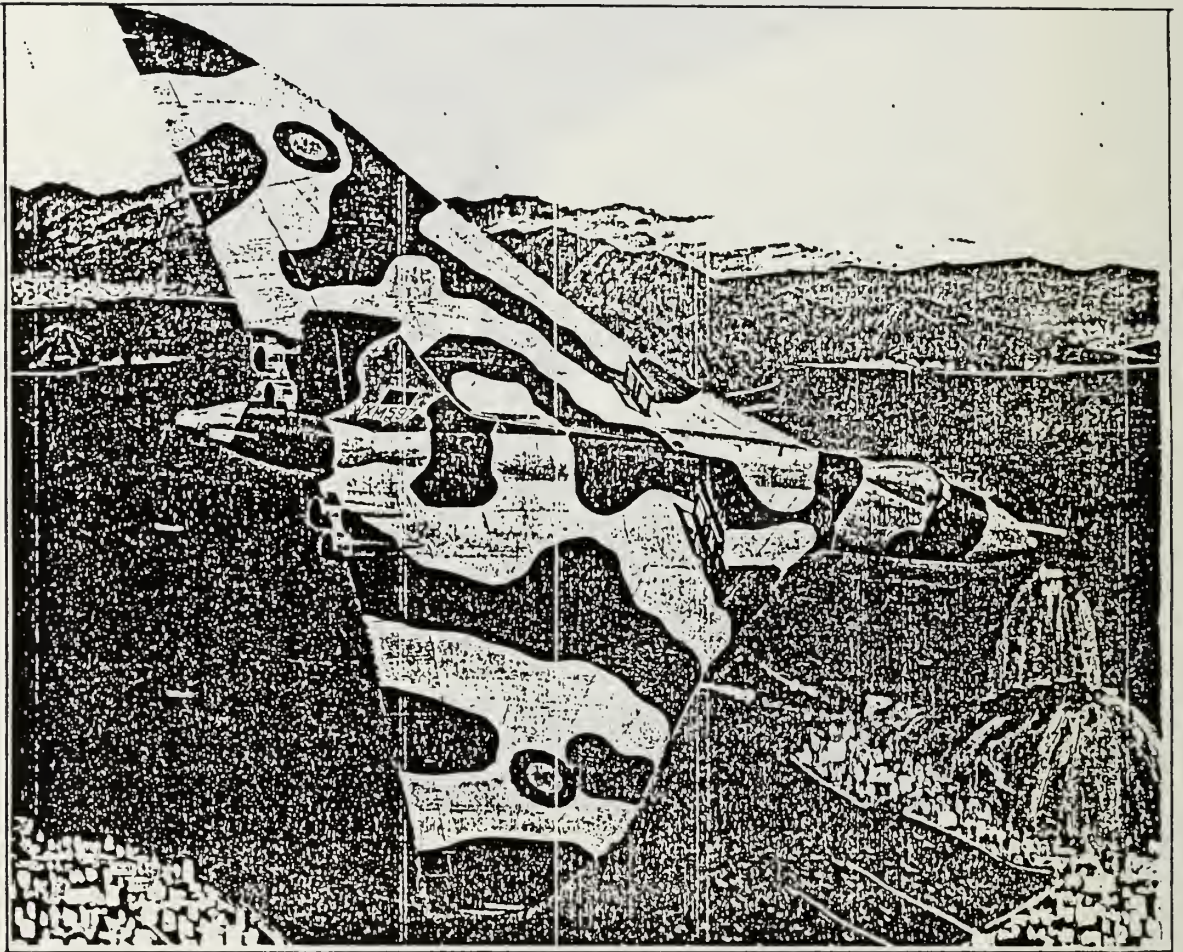

Figure 3.4 - The Vulcan In a Emergency Landing In RIO

2. The attack on Libya Condensed from "Aviation Week & Space Technology - April 21, 1986 - Page 18 to 21".

Demonstration of air power by U.S. forces against suspected terrorist training and bivouac sites in Libya provided the first opportunity for the U.S. air forces to apply many of the technologies incorporated since the end of the Vietnam War.

Approximately 100 aircraft were involved in the coordinated Navy/Air Force strike on the Libyan sites, in which advanced night vision systems, a new generation of precision laser-guided weapons and the capability to conduct successful long-range, low-altitude night strike missions in a high-threat environment were effectively demonstrated.

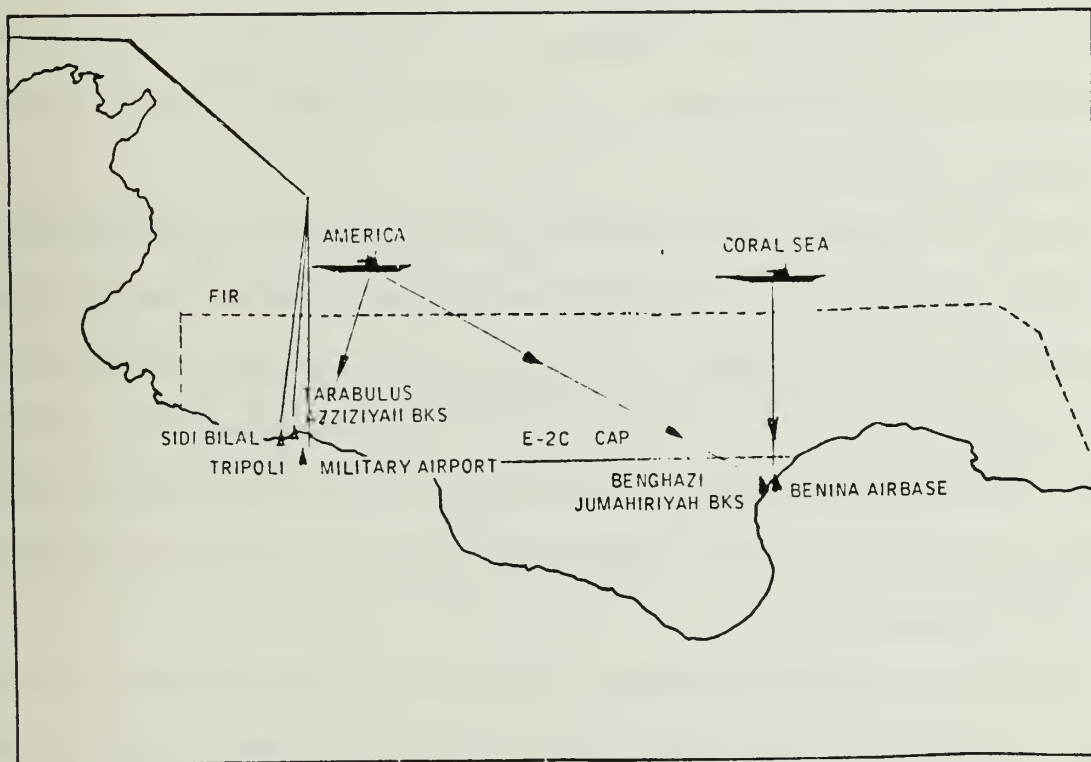

Figure 3.5 - The Target in Libya

Eighteen General Dynamics F-111s took part in the raid on targets in Tripoli, carrying 500- and 2000-lb laser-guided bombs. The USS America and USS Coral Sea, positioned in the Mediterranean Sea launched six and eight Grumman A-6Es for the strike on Benghazi targets, while six McDonnell Douglas F/A- 18s from the Coral Sea and 6 LTV Aerospace A-7Es from the America were used for surface-to-air weapon suppression at both targets.

Combat air patrol over the Gulf of the Sidra was provided by Grumman E-2Cs controlling F/A-18s and Grumman F-14s. Three General Dynamics EF-6Bs were used to jam the missile sites and communications in the two target areas.

The USAF/General Dynamics F-111F and EF-111 strike and electronic warfare aircraft, denied permission by the French government to overfly France, were obliged to follow a circuitous 2500 - nautical miles route from Britain around the west coast of France, Spain and Portugal, over the Strait of Gibraltar into the Mediterranean, and around the northern tip of Africa before reaching Tripoli.

The route across France would have reduced the one-way distance to about 1,300 nautical miles. The additional distance required the Air Force pilots to fly a 13-14 hr mission compared to the six to seven hours they would otherwise have flown. The additional distance also required aerial refueling support. Twenty-eight McDonnell Douglas KC-10s and Boeing KC-135s took off from bases in England to provide four refuelings to the F-111s during the trip to the Libya targets.

Approval to operate the F-111s and McDonnell Douglas KC-10s and Boeing KC-135s from British airfields was given by Britain's Prime Minister Margaret Thatcher. Agreements over the use of bases in England require approval for non-North Atlantic Treaty Organization operations. Both France and Spain denied permission for the Air Force to fly over their countries during the raid.



Figure 3.6 - The Only Available Route to Libya

28 tanker aircraft joined the F-111s on the more than 5-hr. flight from Britain to Libya. The majority of the KC-135 tankers flew from RAF Mildenhall and nine from RAF Fairford. Most KC-10s were stationed in the U.S., but had been flown to Britain to participate in a planned exercise prior to the attack. The F-111As and F-111Fs were refueled four times on the flight to Libya and twice on the return flight.

Prior to the arrival of the Air Force F-111Fs, the Navy launched Grumman Aerospace E-2Cs to provide control and command for the strike activities. The early warning aircraft also were used to detect Libyan MIG fighters that might have been launched against the U.S. aircraft.

The E-2Cs are equipped with either General Electric AN/APS-125 or an improved APS-138 long-range, digital radar with automatic acquisition and tracking capabilities. These radars were upgraded to include an increased antijam capability.

The remainder of this article talks about the mission itself, the weapons used, the communications and controls, the damage, the efficacy, the operation as a whole including one F-111F. that was lost in the raid.

Again, the availability of seaplane carrier aircraft with the capability to land in and take-off from the water, big enough to enclose a fighter/attack squadron with weapons and fuel for an assigned number of missions, with early warning systems and anti-submarine warfare capabilities, would have made it unnecessary to obtain government permission and would have substantially simplified the attack on Libya.

B. FIGHTER/ATTACK AIRCRAFT SIZING CONSIDERATIONS

In order to define an appropriate size for fighter/attack aircraft which could perform an attack mission, based on a seaplane carrier, specific missions will have to be prescribed.

For this work, however, let us consider no specific operations, but only the conventional ones, like shelling, attack with missiles, air combat etc., and this way, let us consider the dimensions, gross weight, maximum speed, maximum attack range and empty weight characteristics of several American aircraft.

1. SELECTION OF FIGHTER/ATTACK AIRCRAFT

Considering the seaplane only as a big cargo transport aircraft to carry the fighter/attack aircraft, let us look for the best choice among these aircraft.

TABLE I

FIGHTER/ATTACK AIRCRAFT SELECTION

FIGHTER/ ATTACK ACFT.	SPAN in FEET	LENGTH in FEET	HEIGHT in FEET	EMPTY WEIGHT in lb	GROSS WEIGHT in lb	MAX. SPEED MACH	ATTACK RANGE n.m
A-4	28	39	15	10 600	22 000	M 1	920
A-7	39	48	16	19 781	42 000	M 1	700
F-4	39	63	16	31 000	60 630	M 2.27	2 300
F-5	28	52	14	9 700	24 000	M 1.6	1 400
F-8	36	54	16	19 700	34 000	M 1.68	370
F-14	64	61	16	37 500	72 000	M 2.34	2 000
F-15	43	64	19	28 000	66 000	M 2.5	1 200
F-16	38	48	16	14 800	33 000	M 1.95	120
F-18	37	56	15	28 000	49 000	M 1.8	550
F-100	39	52	16	22 300	34 800	M 1.3	1 500

TABLE I, CONT.

F-101	40	69	18	28 000	51 000	M 1.85	1 550
F-104	21	54	14	14 000	28 800	M 2.2	300
F-106	38	70	20	23 646	38 250	M 2.31	600
F-111	63	74	17	50 000	119 000	M 2.2	3 100

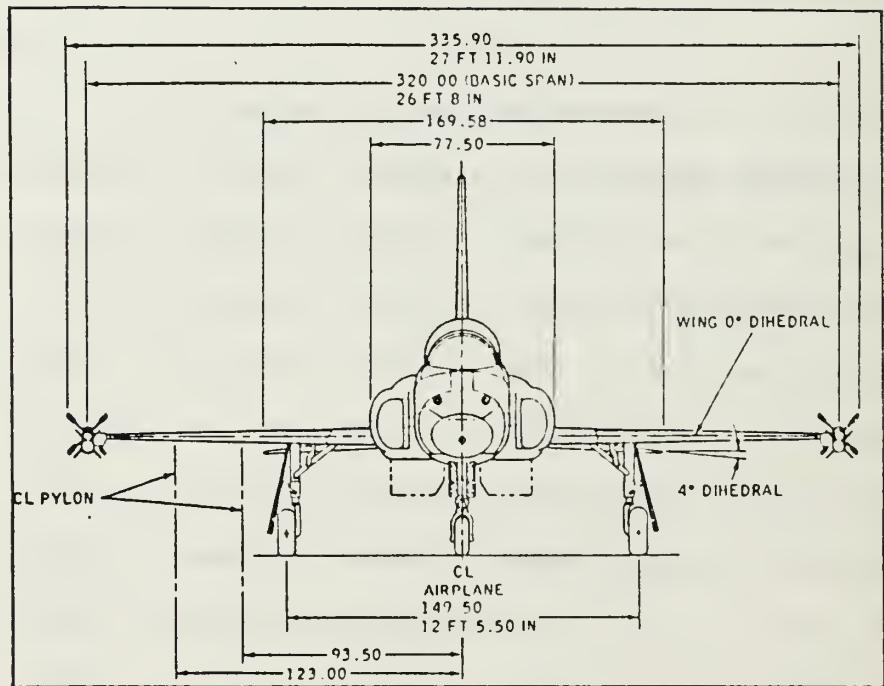

Figure 3.7 - F-5E Principal Aircraft Dimensions

The aircraft with the smallest wing span clearly is the F-104, with the F-5 and the A-4 in second place, having both about 25% more span.

The length and weight are also very important. The A-4 has the smallest length, followed by the F-16, A-7, F-5, F-100 and so on.

The aircraft with the smallest empty weight is the F-5, having an empty weight of 9 700 lb and an additional load capability of 14300 lb, the A-4 is second with 10 600 lb of empty weight and 11 400 lb of additional load capability, the F-104 is third with 14 000 lb of empty weight and 14 800 lb of additional load capability.

The geometric and weight considerations thus tend to favor the F-5 as a strong candidate.

As far as speed is concerned, the McDonnell Douglas F-15 Eagle has a maximum speed of $M=2.5$, followed by the F-14 with $M=2.34$, and so on, the F-5 is in eleventh place with $M=1.6$.

Another very important parameter for seaplane operations is the attack range, since this means that the seaplane, as a mother aircraft, could stay out of the battle theater as much as possible, if the attack range for the fighters were as great as possible.

The F-111 has the best range with 3 100 nautical miles which means 1 650 n.m. in a round trip, followed by the F-5 with 1 400 n.m. or 700 n.m. round trip, the A-4 is third with 920 n.m., whereas the F-104, with only 300 n.m., has to be considered unsuitable for this job.

In accordance with the above considerations the F-5 emerges as the most suitable aircraft. We therefore take the F - 5E as a model, from the available manuals, like T. O. 1F-5E-1.

The main dimensions are seen in Figure 3.7

Surrounding each figure, one can define the minimum area needed for each F-5, Figure 3.8, in each view, frontal, lateral or top, to obtain the volume needed inside the seaplane.

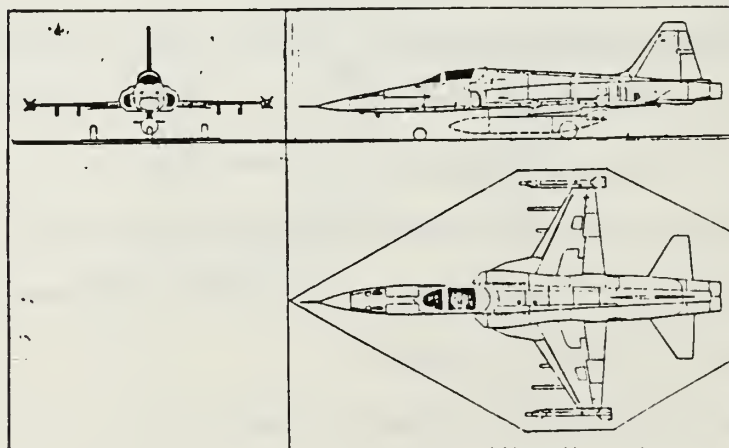
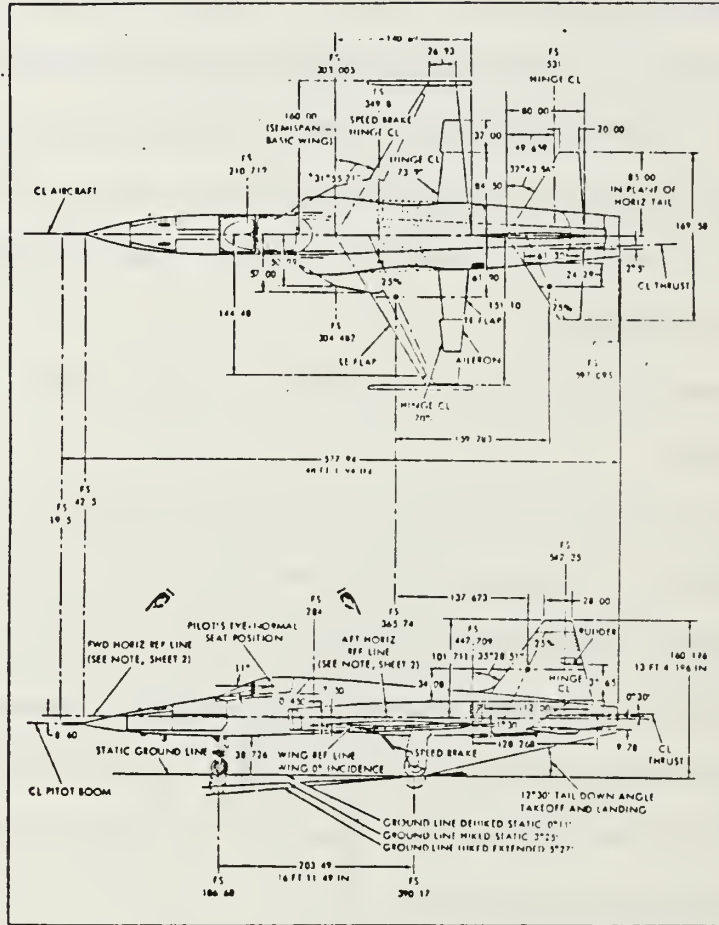

Figure 3.8 Views of the F-5E

2. EXTENDED SAMPLE MISSION PLANNING LOG

Following the normal steps in the Mission Planning for a fighter F-5E, in T. O. 1F-5E-1-Part 10, Appendix A, a typical mission is assumed with 2 wing tip missiles AIM-9, four MK-82 bombs on the wing pylons, a 275-gallon external fuel tank on the centerline pylon, and 560 rounds of 20mm ammunition, giving the F-5E a total gross weight at the starting point of 20,582lb and 11,400lb at the very end of the mission. The fuel spent is 5,575lb, as shown in the Figure 3.9, subtracting from the usable fuel weight the landing fuel reserves of 600lb.

SAMPLE MISSION PLANNING LOG											HI-LO-HI INTERDICTION	
PHASE OF MISSION	POWER SETTING	FUEL USED - LB	TIME	DISTANCE	POSITION	TOTAL GROSS WEIGHT - LB	TOTAL TIME	TOTAL DISTANCE	ALTITUDE - FT	ALTITUDE - FT	ALTITUDE - FT	
3-MIN TAXI 1-MIN RUNUP TAXI-OFF & ACCELERATE	IDLE MIL MAX - MIL	324	7.1	3	START	20,582	0	0	—	—	SL	
					END	20,058	7.1	3	325 KTAS	SL		
CLIMB TO 30,000 FT	MIL	1170	15	105	START	18,888	22.1	108	325 KTAS	30,000		
					END	17,523	46.7	313	501 KTAS	30,000		
CRUISE AT 30,000 FT	0 BS IMN	1365	74.8	205	START	16,732	51.7	313	529 KTAS	SL		
					END	13,001	61.5	241	335 KTAS	39,000		
COMBAT AT SEA LEVEL 0 BS IMN	MIL	790	5	0	START	12,000	90.1	0	505 KTAS	39,000		
					END	11,400	90.1	0	—	SL		
RELEASE BOMBS & TANK PIRE AMMO & MISSILES	—	[3007]	0	0	START	—	—	—	—	—		
CLIMB FROM SEA LEVEL TO 29,000 FT	MIL	725	8.8	72	START	—	—	—	—	—		
					END	—	—	—	—	—	—	—
CRUISE AT LONG RANGE SPEED AT 29,000 FT	0 BS IMN	1001	78.6	241	START	—	—	—	—	—		
					END	—	—	—	—	—	—	—
LANDING FUEL RESERVES	—	600	0	0	START	—	—	—	—	—		
					END	—	—	—	—	—	—	—

<p>• USABLE FUEL WEIGHT</p> <p>INTERNAL 4400 LB</p> <p>CL PYLON TANK 1775 LB</p> <p>TOTAL 6175 LB</p>	<p>[] STORE WEIGHT ONLY</p>
---	------------------------------

DATA BASIS	
• STANDARD DAY	
• ZERO WIND CONDITIONS	
• PYLON FUEL TANK DROPPED WHEN EMPTY	

Figure 3.9 Sample Mission Planning Log for F-5E

Because the F-5E will be launched from the seaplane at 30000 ft the fuel to climb from sea level to 30,000 ft is available for the cruise portion. The fuel for climb amounts to 1170 lb. Since the average value of the fuel used during the cruise portions, inbound and outbound, is .2 n.m./lb or 5lb per nautical mile, one can extend the range by 129 n.m., since $.2 \text{ n.m./lb} \times 1170\text{-lb} = 234 \text{ n.m.}$, but 105 nautical miles are normally flown in the climb to cruise flight. This way, the 313 n.m. previously scheduled in the Sample Mission Planning Log, Figure 3.10, could be extended to $313 + (129/2) = 377.5$ or 377 n.m., Figure 3.11.

This means that these fighters could perform missions up to 377 n.m. from the seaplane, or even more if the seaplane flies toward the operational theater to shorten the meeting time with the fighters.

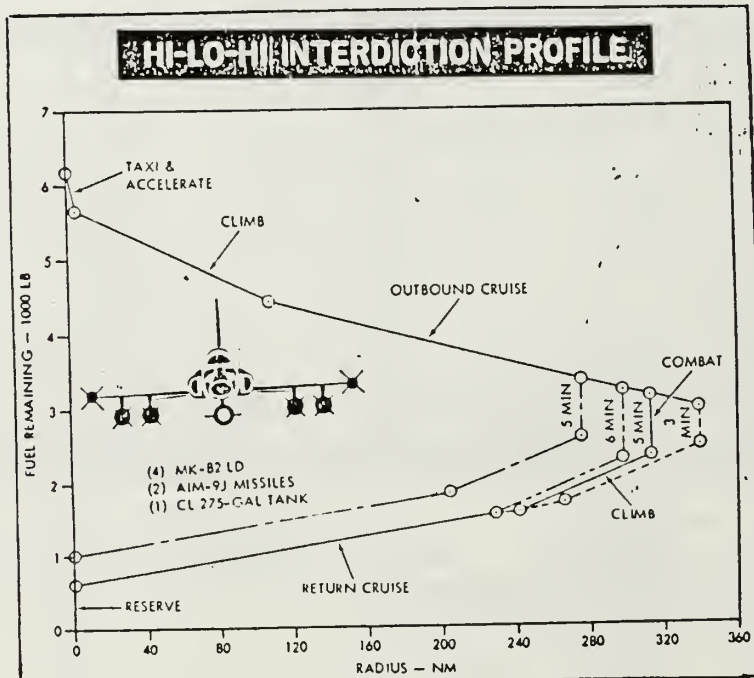

Figure 3.10 Hi-Lo-Hi Interdiction Profile Mission-F5E

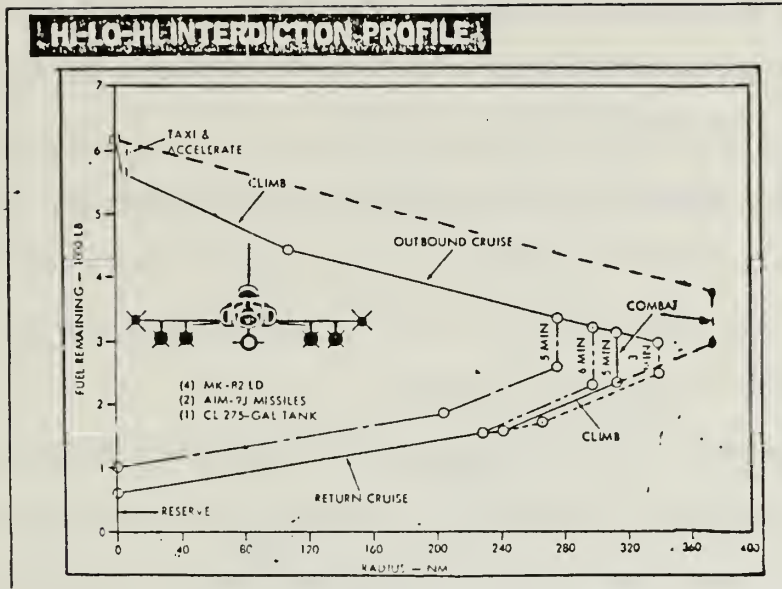

Figure 3.11 Extended HI-LO-HI Interdiction Profile Mission

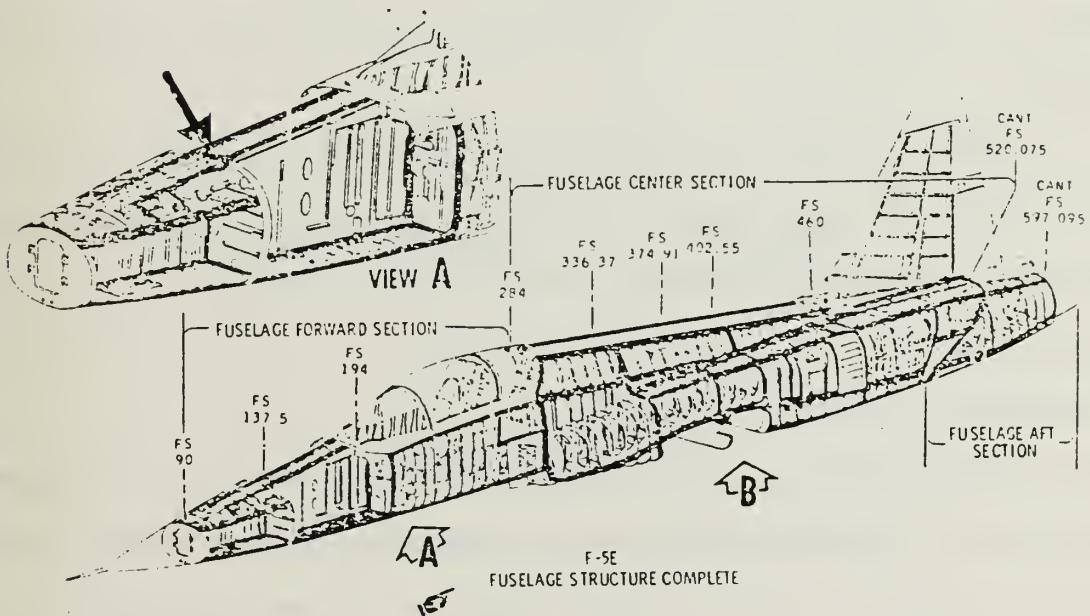

Figure 3.12 Front LRS Engagement Position in the F-5E

3. THE IN-FLIGHT LAUNCH AND RECOVERY (LRS) SYSTEM

The air launch and recovery of small aircraft from inside larger aircraft has been studied in considerable detail by several U. S. aircraft manufacturers in the context of the so-called strategic aircraft carrier concept, using land-based carrier aircraft.

The small aircraft is injected into the air from the fuselage by a proper mechanical extension system. Engine start occurs outside of the fuselage while the small aircraft is still mechanically linked to the mother aircraft or after it has been released.

For recovery the aircraft approaches from below and behind the mother aircraft. The mechanical extension system must be long enough to permit a safe distance between the two aircraft before link-up is achieved. After engine shut-down the small aircraft is retracted into the fuselage.

The detailed design of this launch and recovery system is beyond the scope of this thesis. It may suffice here to refer to the above mentioned studies and to state that the feasibility of such in-flight operations is not in doubt.

Figure 3.12 shows the front part of the canopy, station 137.5, where the F-5 pilot will first engage his aircraft. Additional attachment points to the mechanical extension systems are on the main wings, station 73, as shown in Figure 3.13.

C. THREAT AND DEFENSE CONSIDERATIONS

Since the seaplane is a big carrier aircraft, comparable to or bigger than a Lockheed C-5 or Boeing 747 aircraft, it will be quite vulnerable to aircraft or missile attacks. Its best defense therefore will be its ability to maintain a safe distance from hostile areas. This necessitates its equipment with sophisticated early warning and control systems. In addition,

it will have to carry air-to-air and air-to-surface missiles for self-defense purposes, and seaplane operations will have to be conducted in such a way that enough fighter aircraft are retained to engage hostile attack aircraft.

Furthermore, its susceptibility must be reduced by adding noise jammers, deceivers and expendables. Its signature must be reduced by using the latest state-of-the-art technology, such as special aircraft materials and paints.

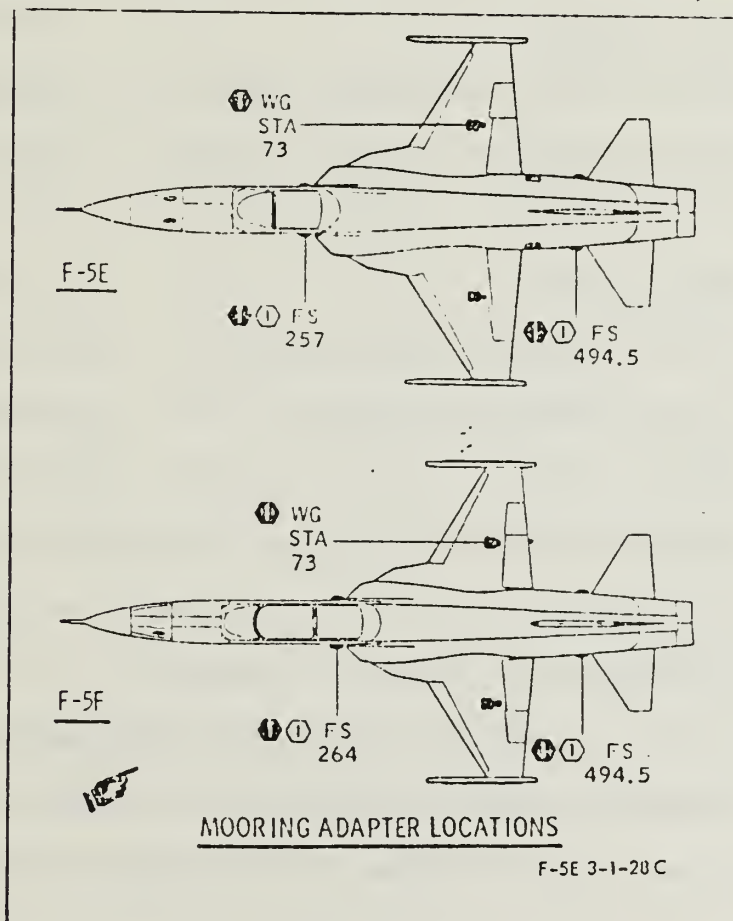

Figure 3.13 Rear LRS Engagement Position in the F-5E

IV. SEAPLANE CONSIDERATIONS

A. GROSS WEIGHT

Let us start out with the assumption that five F-5 aircraft are to be transported by the seaplane.

The total volume needed to accommodate these five aircraft can then be estimated to be 35 ft x 35 ft x 120 ft = 208250 cuft.

The F-5 empty weight, as seen previously, is 9,700 lb. For the F-5E, the total gross weight is 20,582 lb, the fuel weight is 6,175 lb.

This gives a difference of $(20\ 582 - 9\ 700)\text{lb} = 10\ 882\text{lb}$, where 4 707 lb are the payload or weapons.

Assuming that 10 full range missions are to be flown by four fighters, while the fifth aircraft is kept in reserve, one gets the following weight estimates:

5 F-5E empty weight	48 500 lb
4 x 10 x 4 707 lb total weapons missions	188 280 lb
4 x 10 x 6 175 lb total fuel missions	247 000 lb
total weight	483 780 lb

Let us consider a crew of five people to operate the entire seaplane, five more to pilot the fighters and five for maintenance and support services, hence a total of 15 people or $15 \times 200\ \text{lb} = 3\ 000\ \text{lb}$.

If we consider an additional 13,220 lb for self-defense weapons and ammunition for the seaplane, the total cargo weight reaches 500 000 lb.

Studying some of the U.S. Commercial Transports, one can get:

TABLE II

U.S. COMMERCIAL TRANSPORT AIRCRAFT

ACFT	MODEL	CARGO lb	EMPTY WEIGHT	GROSS WEIGHT	Wg/CARGO	Wg/We
BOEING	707/320C	96 800	134 000	332 000	3.43	2.47
"	727C	46 600	89 500	170 000	3.64	1.90
"	727QC	46 600	92 500	170 000	3.64	1.84
"	747F	220 000	327 000	680 000	3.09	2.08
DOUGLAS	DC-7F	33 000	68 292	125 800	3.81	1.84
"	DC-8F	95 124	126 173	325 000	2.57	3.42
LOCKHEED	1049H	30 000	104 000	137 000	4.57	1.31
"	2049C	29 712	73 788	130 000	4.37	1.76
"	1649A	33 000	122 850	160 000	4.84	1.32
"	100	46 741	70 881	155 000	3.31	2.18
"	200	88 574	129 270	323 600	3.65	2.50
"	300/101	123 577	153 224	408 000	3.30	2.66
"	500/107	330 000	327 460	830 000	2.51	2.53
"	500/114	221 865	318 295	728 000	3.28	2.29
AVERAGE VALUES					3.57	2.15

This shows that the average ratio gross weight/cargo is 3.57 and the average ratio gross weight/empty weight is 2.15.

With these values, a rough estimate for the seaplane gross weight is $W_g = 1,785,000$ lb and the empty weight $W_e = 830,000$ lb.

The difference between W_g and W_e then is 920 000 lb, of which 500 000 lb are the estimated "cargo" and the other 420 000 are available for fuel and the other accessories.

B. HULL CONSIDERATIONS

A suitable flying boat or seaplane hull must satisfy the following reserve requirements in moderately bad weather:

1 - be stable, controllable and water-tight.

2 - take-off from the water in sea-state 3 in a very short time and distance, say less than 1 minute and less than 1 mile, with no structural damage by waves or spray to hull, wings, tail, turbines, etc., and be controllable during the take-off.

3 - have low drag at cruising speed.

4 - be landable in sea-state 3 without excessive landing shock or spray, and be controllable.

Normally, when we try to satisfy these requirements other characteristics will suffer and the designer's problem is to select the best compromise between them.

Short take-off time and distance is a most severe requirement, and for the best of the hulls, the ratio of maximum water resistance to the buoyant force is in the vicinity of .15 to .20.

Longer and narrower hulls for best compromise performance with a value of $L/B = 15$, as shown in the figure 4.1, have been found superior in many respects. A much sharper V-bottom with "deadrise" angles up to 40 degree, was also found to reduce the landing shock without adverse take-off or spray effects.

As the beam was found to require a minimum of 35 ft inside the seaplane, let us take 38 ft for the real value of the beam, and with $L/b = 15$, the L value becomes 570 ft.

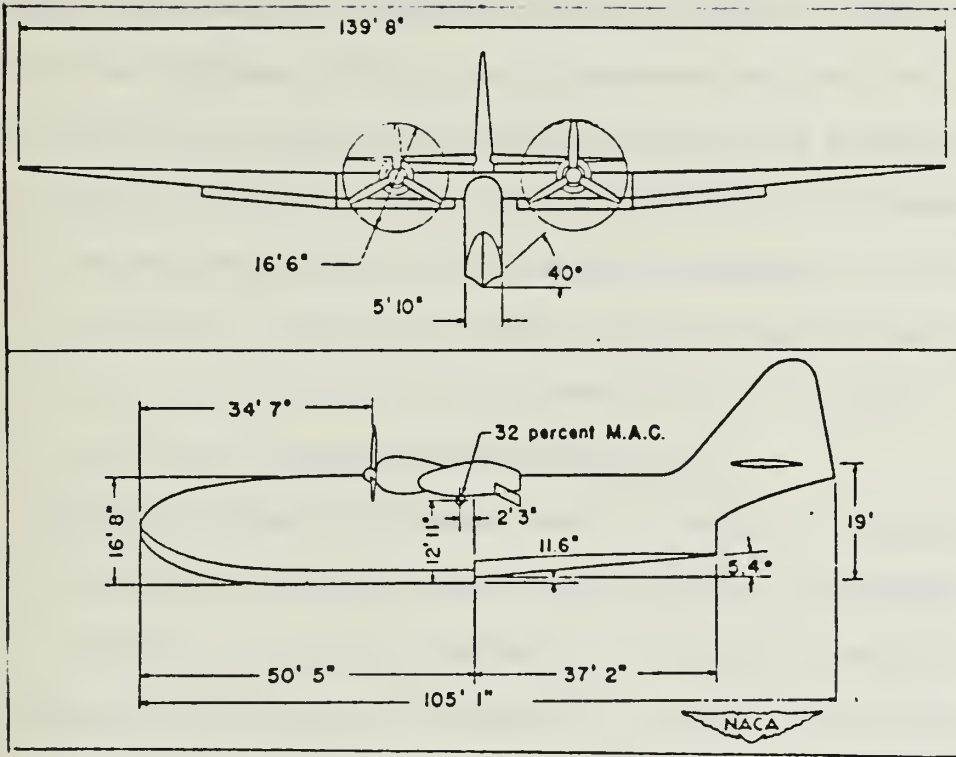

Figure 4.1 Layout of a Hypothetical Flying Boat

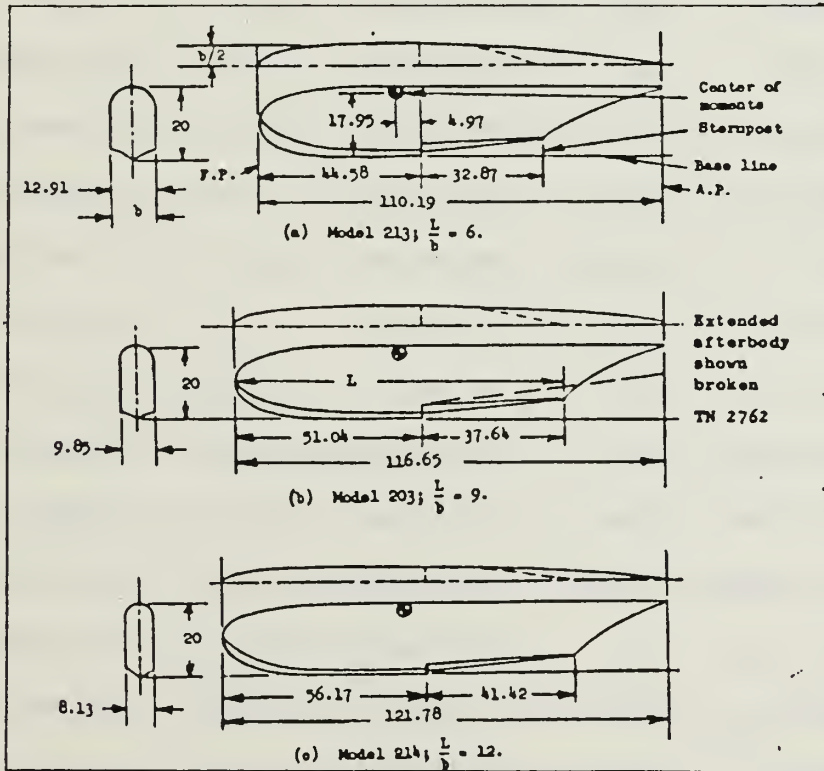

Figure 4.2 Some Flying Boat Hulls (NACA TN 1686)

As this value is too high for our purpose, let us consider other geometries, as shown in the figure 4.2, for $L/b = 6, 9$ and 12 , respectively.

As our "package" is a box of $35 \text{ ft} \times 35 \text{ ft} \times 170 \text{ ft}$, or a box in which the length is 4.86 times the width or the height, the shortest one of the hulls shown in Fig. 4.2 is the optimal one.

Selecting the geometry of model 213, $L/b = 6$, one obtains $L = 376 \text{ ft}$, $b = 38 \text{ ft}$ and the height $h = 65 \text{ ft}$, for the real hull.

TABLE III

U. S. GAS TURBINE ENGINES

MANUF.	MODEL	TYPE	MAX. POWER	ESP. CONS.	DRY WEIGHT
GE	CF6-45A2	AFF	46 500 LB	.354	8 768 LB
GE	CF6-50A	AFF	49 000 LB	.385	8 580 LB
GE	CF6-50C	AFF	51 000 LB	.368	8 721 LB
GE	CF6-50C1	AFF	52 500 LB	.371	8 721 LB
GE	CF6-50CE	AFF	52 500 LB	.371	8 768 LB
GE	CF6-80A	AFF	48 000 LB	.344	8 310 LB
GE	CF6-80C	AFF	55 000 LB	9 350 LB
P&W	JT9D-7A	AFF	46 250 LB	.364	8 850 LB
P&W	JT9D-7F	AFF	48 000 LB	.367	8 850 LB
P&W	JT9D-7J	AFF	50 000 LB	.370	8 850 LB
P&W	JT9D-7Q	AFF	53 000 LB	.375	9 295 LB
P&W	JT9D-7R4D	AFF	48 000 LB	.340	8 905 LB
P&W	JT9D-7R4E	AFF	50 000 LB	.344	8 905 LB
P&W	JT9D-7R4G2	AFF	54 750 LB	.360	9 100 LB
P&W	JT9D-7R4H1	AFF	56 000 LB	.364	8 870 LB
P&W	JT9D-20	AFF	46 300 LB	.349	8 450 LB
P&W	JT9D-59A	AFF	53 000 LB	.375	9 140 LB

C. POWER DETERMINATION

For flying boats which are powered by turbojet or turbofan engines the basic (δ/r) hump must be the primary consideration.

With the most favorable planing-tail flying boat hulls yet devised (δ/R) hump has not exceeded 6, and to leave some margin for acceleration at the hump it is estimated that W/T must be approximately 4 or 5.

For $W/T = 4$, with $W_g = 1,785,000$ lb as previously determined, the thrust will be $T = W_g/4 = 446\ 250$ lb and for $T = W_g/5 = 357\ 000$ lb. Let us adopt an intermediate value like 400 000 lb of thrust.

From "Aviation Week & Space Technology", March 9, 1981, one can select several U.S. Gas Turbine Engines with 45 000 to 56 000 lb of available thrust. If we choose the model JT9D-7R4H1 from Pratt & Whitney Aircraft Group - Commercial Products Division, we will have available 56 000 lb of thrust for each engine with a specific fuel consumption at maximum power of .364 lbm/sec, a maximum envelope diameter of 97 inches, a maximum envelope length of 153.6 inches with a dry weight of 8,870 lb.

The total engines needed are eight since the amount of thrust required will be 400 000 lb. With this number of engines the total power available during take-off will be $8 \times 55\ 000 = 440\ 000$ lb or a 10% of reserve power.

D. RANGE AND ENDURANCE

As .364 lbm/sec is the maximum fuel flow required during take-off or maximum power required situations, let us take a value of 80% of this amount for regular flight operations and this way, with eight engines, the average fuel consumption will be 2.3296 lbm/sec.

From the 420 000 lb allotted to fuel and miscellaneous purposes, let us take 400 000 lb for fuel. Hence $400\ 000/2.3296$ gives 171 703 sec or more than 47 hours of flight operation.

Considering an average speed of 550 mph, let us first compute the amount of time it needs to fly in the war theater.

From the Extended Sample Mission Planning Log, we defined a 377 nautical miles range mission for the F-5E, with a consumption of 5 lb per nautical mile, which represents a maximum of 75 minutes for each F-5 mission. For ten missions, as previously scheduled, this means 750 minutes or 12 hours and 30 minutes of operation. Let us consider about 35% more for the seaplane operations since it must take-off, climb, land, etc., and this way will spend about 17 hours in the war theater.

As this aircraft could fly for 47 hours, the 17 hours in the operational area reduces this amount to 30 hours. Reserving 2 hours as safety margin due to adverse flight conditions, the 28 remaining hours will be available to go to the conflict zone and come back to the base. This means a 14 hour flight radius and, at a speed of 550 mph, a range of 7 700 nautical miles. Hence this aircraft is able to take-off from Ascension Island, to go to the Falklands, to support 10 complete F-5 attack missions and to return to Ascension Island without refueling.

E. COMPARISON WITH OTHER GIANT AIRCRAFT PROJECTS

In 1977 Japan's Shin Meiwa Industry Company announced the study of giant flying boats seating 1200 passengers (Ref. 10). This "giant seaplane" concept envisioned a triple-decked, 1,04 million lb gross weight transport aircraft, cruising at 37,000 ft at Mach 0.85 for a range of 3500 nautical miles. This flying boat came out to be almost 300 feet long, with a fuselage diameter of 27.6 feet and a wing span of 256 feet. It was designed to have a super-critical wing and six advanced turbofans mounted above the wing to incorporate the upper surface blowing propulsive lift concept, as shown in Figure 4.4. The six advanced high-bypass-ratio turbofan engines were assumed

to be in the 77,000 lb thrust class. The upper surface blowing flaps were designed to provide good STOL capability, allowing landings and take-offs in sea-state 3, with maximum wave height of 5 feet. The use of composite materials was planned, both as a weight saving measure and a means of resisting salt corrosion. The company estimated to achieve weight savings of 26 percent in the wing, 15 percent in the hull, 18 percent in the fin, 21 percent in the tail-plane, 16 percent in the engine nacelle, and 15 percent in the floats. Special attention was given to improvements in the hull design in order to minimize aerodynamic drag and weight penalties. The spray-suppression groove along the chine of the hull forebody was designed to be covered with a retractable fairing to reduce drag.

Lockheed-Georgia Company explored the conversion of the C-5A aircraft to a seaplane configuration. Also, it explored the use of giant aircraft as carriers of missiles and small aircraft for air launch and recovery. One of its designs envisioned an aircraft with a take-off gross weight of 790,525 lb, a wing span of 382 feet, a wing area of 10,229 square feet, a length of 274 feet, a height of 68 feet, designed to fly a 48 hour loiter mission carrying five air launched fighters internally. The fighter aircraft were envisioned to have a combat radius of 450 nautical miles, a launch weight of 18600 lb, a maximum speed of 1.4M, a cruise speed of 0.88M, a wing span of 22.5 feet, a wing area of 153 square feet, a length of 35 feet, and a height of 9 feet.

F. RE-EVALUATION OF SEAPLANE SIZING

Seaplanes in the 1.7 million lb take-off gross weight category clearly require a major development effort which is unlikely to be undertaken in the near future. Instead, it is more logical to base the seaplane carrier concept on the presently available aircraft technology and hence on Lockheed C-5 or Boeing 747 size aircraft. This technology is well understood and the

only changes needed are the seaplane conversion and the incorporation of the launch and recovery system.

Let us therefore assume that five full range missions are to be flown by one fighter, thus giving the following weight estimates:

F-5E empty weight	9700 lb
5x4707 lb total weapons missions	23535 lb
5x6175 lb total fuel missions	30875 lb
Total weight	64110 lb

For five missions approximately six hours and 30 minutes of flight operations are required. Adding again 35 percent more to obtain the total time spent in the war theater gives nine hours. Assuming 150000 lb of fuel being available for the seaplane and an average fuel consumption of 1.165 lbm/sec for four JT9D engines we obtain $150000/1.165$ or 128755 seconds, or approximately 36 hours of total flight time. Reserving again two hours as safety margin due to adverse flight conditions 25 hours will be available to go to the conflict zone and come back to the base. Hence, at a speed of 550 mph, this produces a range of 6875 miles, again sufficient to reach the Falklands from Ascension Island.

The current Lockheed C-5 aircraft has the following dimensions: Fuselage Height: 20 ft; Width: 19 ft; Length 121 ft. Hence, if folding wings are used, one F-5 aircraft can be easily accommodated in the C-5 fuselage, since the maximum payload capability is 291,000 lb. Having assumed only a payload of 64,110 lb for the seaplane carrier mission, the maximum range is therefore available for this mission. The assumption that only one F-5 aircraft is to be carried and launched from the C-5 size seaplane clearly is very conservative.

G. POSSIBLE SEAPLANE OPERATIONS

Having established that Lockheed C-5/Boeing 747 size seaplanes are capable of carrying at least one F-5 aircraft to targets at distances of about 3500 miles, to remain on station for about nine hours, and to attack the target five times, it remains to describe typical flight operations. Since a minimum of four F-5 aircraft is required for a typical mission, a minimum of five or six seaplanes carrier aircraft is needed. This leaves at least one or two F-5 aircraft available for the protection of the seaplanes in the war theater or for attack purposes if no seaplane protection is deemed necessary.

Due to the potential vulnerability of the seaplanes it will be advisable to equip the planes with early warning capabilities or to add a separate AWACS plane to the carrier group.

The missions considered up to now were based on the assumption that the seaplanes would take off from a land base (i.e. have amphibian capability) and would remain airborne while on station for a total flight time of 36 hours. The use of seaplanes rather than land planes provides the mission planner with the flexibility to position his planes closer to the target for a surprise attack after an extended period of sea-sitting if the seastate at the chosen location permits him to do so. Also, the time on station can be extended by periods of sea-sitting rather than remaining airborne if the planner should choose to use this option.

H. SEAPLANE CONFIGURATION

The most suitable seaplane configuration is likely to be similar to the giant seaplane proposed by Shin Meiwa, shown in Figure 4.3. It would have shoulder-mounted engines so that it could utilize the upper surface blowing propulsion lift concept, which was first used on the Boeing AMST YC-14 aircraft. The details of this concept are shown in Figure 4.4 and 4.5. This

technology therefore is already well advanced and few development problems are likely to be encountered. Furthermore, as pointed out by Artigiani (ref.27), advances in seaplane hull shape designs make seaplanes competitive with landplanes for gross weights above 500,000 pounds. Maintenance problems were also largely solved during the late 1950's and 1960's. New metals and experience in joining compatible metals reduced the opportunities for corrosion to occur. Also, chemical coatings added protection to exposed areas. The use of the upper surface blowing propulsion concept in combination with large seaplanes greatly minimizes engine corrosion problems.

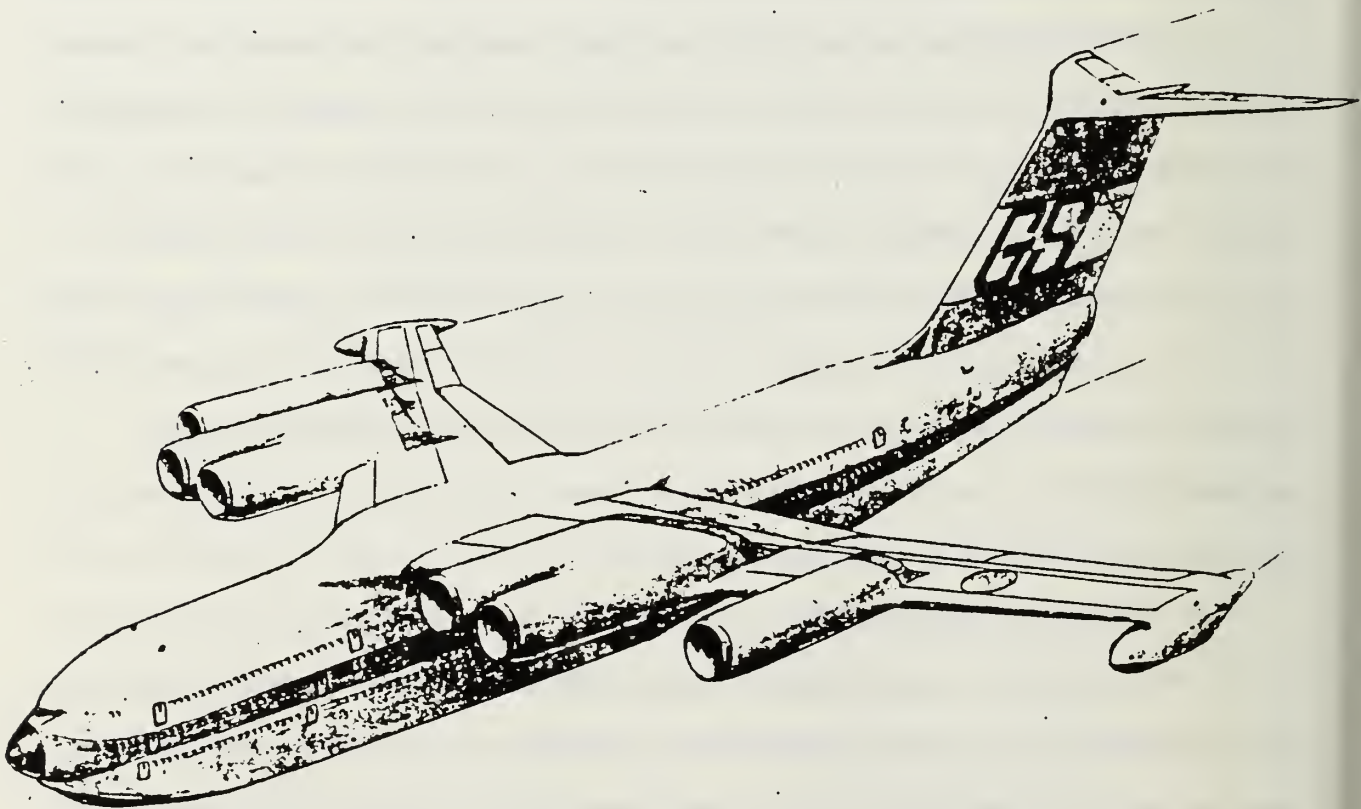

Shin Meiwa giant seaplane concept envisions a three-deck flying boat nearly 300 ft. long and seating about 1,200 passengers on three decks. Artist's concept shows how six advanced turbofans would be above-wing mounted to facilitate employment of the upper surface blowing propulsive lift concept. Span of the supercritical wing would be about 256 ft

Figure 4.3 Giant Seaplane Proposed by Shin Meiwa Company

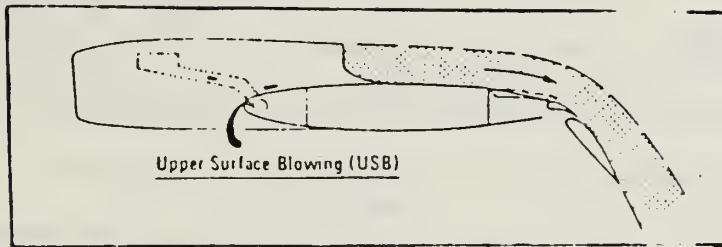

Figure 4.4 Upper Surface Blowing (USB)

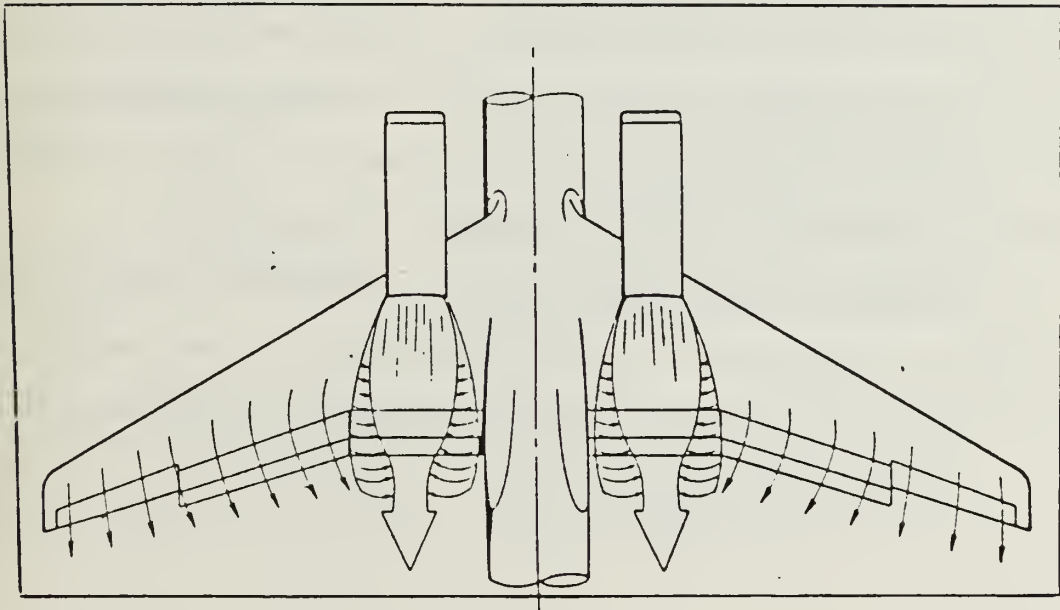

Figure 4.5 USB Flow Characteristics

V. SUMMARY

Seaplanes faced a variety of technical problems after World War II. However, it was not these problems which led to the gradual demise of these aircraft. On the contrary, as pointed out by Artigiani (Ref.18), technical improvements and alterations in the environment in which all airplanes had to operate soon produced designs for seaplanes which made them equals of land-or carrier based aircraft. Reference 19 showed that by the 1960's seaplanes could be produced for the same amount of money with the same payload capacity per unit of gross body weight as a land plane. In addition, a further study, Reference 20, concluded that sea planes could deliver the same bomb weight as carrier task forces at 1/5 the cost in dollars and 1/20 the cost in dollars. A Lockheed study, Reference 21, found that strategic objectives could be achieved by seaplanes at a cost of about 1/40 that of land-based aircraft and 1/13 that of carrier-basing. Also, seaplanes were found to be the most effective vehicle for the ASW mission.

Artigiani concluded that internal naval policies, experiences during World War II, and problems arising from the financing, developing, and designing of seaplanes tended to encourage support for land-or carrier-based aircraft, leading to the virtual abandonment of seaplanes.

In this thesis, Platzer's proposal (Reference 22) to use giant seaplanes as carriers of fighter/attack aircraft was examined in some detail, leading to the conclusion that this concept appears to warrant further detailed study.

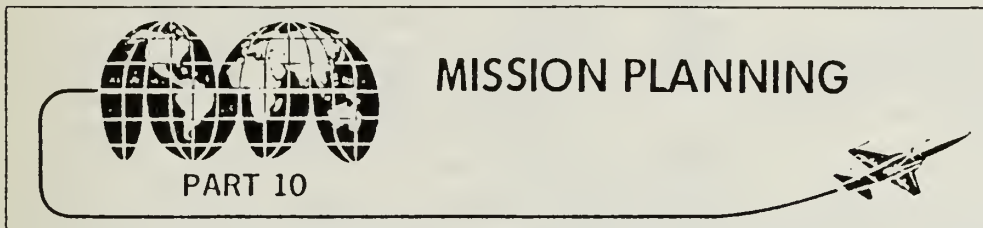

TABLE OF CONTENTS

	Page
Purpose of Mission Planning	A10-1
Mission Planning Sample Problem	A10-1
Sample Mission Planning Log	A10-5
Hi-Lo-Hi Interdiction Profile	A10-7
Takeoff and Landing Data Card	<u>A10-9</u>

Page numbers underlined denote charts.

PURPOSE OF MISSION PLANNING

The purpose of mission planning is to obtain optimum performance for any specific mission. Optimum performance will vary, for example, from maximum time on station to maximum radius with no time on station. Exact requirements will vary, depending upon the type of mission to be flown. The use of parts 1 thru 8 is illustrated in this part by means of sample problems.

maximum thrust followed by a military thrust climb on course to optimum cruise altitude. Cruise is at constant altitude at long range speed.

NOTE

The centerline store must be retained until inboard MK-821D bombs are released (see section V, Inflight Carriage and Sequencing Limitations)

MISSION PLANNING SAMPLE PROBLEM

NOTE

The following problem is an exercise in the use of the performance charts. It is not intended to reflect actual or proposed tactical missions.

At the target area, a 5-minute sea level combat fuel allowance is calculated with military thrust at 0.8 mach number. After bombs, missiles, centerline store, and ammunition are expended, a military thrust climb to optimum cruise altitude and a constant altitude long-range cruise speed cruise to the base are calculated, allowing a 600-pound fuel reserve at altitude over the base for descent and landing. Zero wind and standard day conditions are assumed throughout the mission except for takeoff and landing.

SAMPLE PROBLEM

The problem is to determine the maximum target radius available for an F-5E configured with wingtip missiles, four MK-821D bombs on the wing pylons, a 275-gallon external fuel tank on the centerline pylon, and 560 rounds of 20mm ammunition. For simplicity, no descents are included in the problem. Takeoff is made with

Supplemental Data

- a. The loaded gross weight with (2) AIM-9J missiles, 560 rounds of 20mm ammunition, (4) MK-821D bombs, (1) 275 gallon centerline fuel tank, (5) pylons, and full intercal fuel is 20,582 pounds. Tabulating the weight data from FAI-7 results in the following:

Appendix I

T.O. 1F-5E-1

Part 10. Mission Planning

	WT - LB
1- 5F with Launcher Rails	15,050
(2) AIM-9J Missiles	340
(4) MK-82LD Bombs	2124
(1) 275-gal CL Tank (full fuel)	2004
(5) Pylons (170 + 244 + 256)	670
560 Rounds of 20mm Ammunition (with links)	394
Total Gross Weight	20,582

- b. Usable fuel load is 6175 pounds. Aircraft weight with zero fuel and without four MK-82LD bombs, 314 pounds of ammunition, the 275-gallon pylon tank, and the two AIM-9J missiles is 11,400 lb.

General Comments

- a. This type of mission cannot be solved directly as none of the conditions at the maximum radius point, such as fuel used, gross weight, or radius, is known. The problem must be worked from the beginning and the end of the mission, starting with the takeoff weight and empty weight (zero fuel) and working toward the weight at the start of combat. When the radius from takeoff to combat equals the radius from combat back to the base, the problem is solved.
- b. As the outbound weight and drag are greater than the weight and drag during the return to base, more fuel is required to reach the combat zone than to return. Therefore, as a starting point, assume that 51 percent of the total fuel has been used when combat begins. This will determine the aircraft weight at this point and both the outbound and return radii can be computed. By comparing the two radii, the combat weight can be adjusted and the computations revised until the mission is balanced. The fuel used during combat and during the climb to cruise altitude after combat is hardly affected by small adjustments in the combat weight; therefore, the problem of adjusting the two radii to match is quickly resolved.
- c. As the maximum radius of this aircraft is considerably in excess of the distance shown in FA4-1, this mission is not in the short range category for planning purposes.

Takeoff and Accelerate

The mission is now worked from takeoff to the combat zone. Drag Index at takeoff from FA1-1:

Basic Aircraft Configuration	2
(2) AIM-9J Missiles	16
(1) CL 275 gal Tank	32
(2) MK-82LD Bombs (inboard)	70
(2) MK-82LD Bombs (outboard)	120
Drag Index	120

Takeoff factor is 12 (FA2-4) for standard day at Sea Level. Takeoff time, fuel and distance (FA3-1) required before reaching MIL thrust climb:

Taxi Fuel Flow	18 lb/min
Estimated Taxi Time	5 min
Taxi Fuel Allowance (5 X 18)	90 lb
Static Mil Thrust	
Runup Time	1 min
Engine Runup Fuel Allowance	119 lb

Total Takeoff Allowance

Gross Weight at Brake Release	20,582 (90 + 119)
	= 20,373 lb
Time to Accelerate to Mil Climb Speed	1.1 min
Fuel	315 lb
Distance	3 nm
Start Climb Weight	20,373 - 315 = 20,058 lb

Climb to Optimum Cruise Altitude

Referring to FA3-4 sheets 1 and 2

Start Climb Weight	20,058 lb
Drag Index	120
Fuel to Climb	1170 lb
Time to Climb	15 min
Distance to Climb	105 nm
Weight at End of Climb	18,888 lb
Altitude at End of Climb (FA4-2)	30,000 ft

Determination of Gross Weight at Start of Combat

Total usable fuel for the mission is 6175 lb. Total fuel used before start of combat: 6175 x 0.51 = 3149 lb. Therefore, with 51% of the fuel used the gross weight at start of combat is: 20,582 - 3149 = 17,433 lb.

Cruise to Start of Combat

Cruise Altitude	30,000 ft
Weight at Start of Cruise	18,888 lb
Weight at End of Cruise (estimated for start of combat)	17,433 lb
Fuel for Cruise (18,888 - 17,433)	1455
Average Cruise Weight	18,161 lb
Drag Index	120
Specific Range (FA4-6, sheet 2)	0.150 nm/lb fuel
Cruise Range (0.15 x 1455)	218 nm
Cruise Mach number (limited by configuration)	0.85 mach
Cruise Time (FA4-6, sheet 1)	26 min

Change in Gross Weight During Combat

For the purpose of obtaining the fuel used during 5 minutes of combat at 0.8 mach at military thrust at sea level, use FA8-1

Combat Altitude	Sea Level
Combat Speed	0.80 MN
Combat Fuel Flow	158 lb/min
Fuel Used in 5 Min	158 x 5 = 790 lb
Bomb Weight	2124 lb
Ammunition Weight	314 lb
(2) AIM-9J Missiles	340 lb
Empty centerline tank	229 lb
Weight Loss During Combat	790 + 2124 + 314 + 340 + 229 = 3797
Estimated Weight at End of Combat	17,433 - 3797 13,636 lb

Total Outbound Distance at Start of Combat

	Distance nm	Time min
Takeoff and Acceleration	3	7.1
Climb to Cruise Altitude	105	15
Cruise at 30,000 ft to Start of Combat	218	26
Total Outbound Distance and Time to Combat	326	48.1

Climb to Optimum Altitude and Cruise to Base

The mission must now be worked from empty weight (zero fuel) back toward end of combat. The drag index after combat and for the remainder of the mission is:

Basic Aircraft Configuration	2
(2) Launcher Rails	1
(2) Outboard Pylons	53
(2) Inboard Pylons	14
(1) Centerline Pylon	70
Drag Index	70

Weight with zero fuel and without four MK-821D bombs, 314 pounds of 20mm ammunition, external fuel tank, and two AIM-9J missiles is 11,400 pounds.

Weight over base at end of cruise: 11,400 + 600 = 12,000 lb.

The return climb and cruise to base can now be calculated.

Start climb weight at end of combat: 13,636 pounds.

Using FA3-4, sheets 1 and 2, climb to 39,000 feet

Drag Index	70
Fuel to Climb	725 lb
Time	9.8 min
Distance	72 nm
Start Cruise Weight (13,636 - 725)	12,911 lb
Cruise Altitude (FA4-1)	39,000 ft
End Cruise Weight	12,000 lb
Average Cruise Weight	12,456 lb
Specific Range (FA4-6, sheet 2)	0.240 nm/lb of fuel
Cruise Fuel	911 lb
Cruise Range (911 x 0.240)	219 nm
Cruise Time	26.2 min
Total Range to Base (219 + 72)	291 nm

Balancing the Mission

Using the estimated combat weight of 17,433 lb, the ranges out and back are:

Range Out	326 nm
Range Back	291 nm
Difference	35 nm

In order to balance the mission, combat weight must be increased to decrease the range out and increase the range back. An average value of the fuel used during cruise is $(0.15 + 0.240) : 2 = 0.2$ nm/lb, or 5.0 lb per nm. The combat weight must

Part 10. Mission Planning

be increased only sufficiently to account for half of the 35 nm difference.

Fuel for 18 nm $18 \times 5.0 = 90$ lb

The cruise to combat weight range leg must be shortened and the inbound leg must be lengthened for the effect of 90 lb fuel change.

Therefore:

Outbound

Change of Range $15 \times 9.0 = 13$ nm
 Cruise Range $218 - 13 = 205$ nm
 Total Range $326 - 13 = 313$ nm

Inbound

Change of Range $0.240 \times 9.0 = 2.2$ nm
 Cruise Range $219 + 2.2 = 241$ nm
 Total Range $291 + 2.2 = 313$ nm

The mission is now balanced and the mission radius is 313 nm. A final adjustment of the time to cruise would result in the following values:

Outbound Range 205 nm
 Cruise Time 24.6 min
 Inbound Range 241 nm
 Cruise Time 28.6 min

A summary of the balanced mission is shown in FA10-1.

Alternate Method of Balancing Mission

An alternate method of balancing a mission of this type, where it is required to determine the maximum range of the aircraft, is to solve a very simple equation, which states that the total range outbound is equal to the total range inbound. Referring to the Sample Mission Planning Chart in FA10-1, most of the fuel and range values for the various phases of the mission are readily calculated by knowing the ground rules or the particular conditions of the flight plan pertaining to these phases. For instance, the range during cruise while using fuel from a certain pylon tank will be determined by the quantity of fuel available in that tank. When the chart shown in FA10-1 is filled in with all the parts of the mission that can be determined from the ground rules, there will be one outbound cruise phase just prior to combat and one inbound cruise phase (in this case, the entire inbound cruise leg) whose distances are unknown. These two cruise legs must now be determined so

that the total distance outbound is equal to the total distance inbound. The fuel available for these two cruise legs is that amount of the total mission fuel remaining after all the other mission phases are determined, and is found as follows:

Known Amount of Fuel Used

Start, Taxi, Takeoff	521
Climb	1170
Combat	790
Climb-Cruise to Base	725
Reserve	600
	3809 lb

Total Mission Usable Fuel 6175 lb

Fuel Available for the Two Unknown Cruise Legs
 $(6175 - 3809) = 2366$ lb

Although 2366 lb of fuel is available for the two cruise legs, it is not yet known how this fuel is divided between the two legs as to balance the mission. For this reason, the average cruise weight used to determine the specific range for each of the two cruise legs will have to be estimated for the first try and may have to be slightly adjusted in a second calculation if a more accurate value of specific range is required. Assume that 60% of available fuel is used outbound (1420 lb).

Data for the two unknown cruise legs are as follows:

Average Cruise Weight Outbound
 $18,888 \div (1420 \div 2) = 18,178$

Cruise Specific Range Outbound (FA4.6, sheet 2)
 0.150 nm/lb

Average Cruise Weight Inbound
 $12,000 \div (946 \div 2) = 12,473$

Cruise Specific Range Inbound (FA4.6, sheet 2)
 0.240 nm/lb

Total Known Distance Outbound

Taxi, takeoff	3
Climb	105
	108 nm

Total Known Distance Inbound 72 nm

To set up the equation used to balance the mission:

Let X = pounds of fuel available for the outbound cruise leg

$2366 - X$ = pounds of fuel available for the inbound cruise leg

$0.150 \times$ = outbound cruise leg in nm

$0.240 (2366 - X)$ = inbound cruise leg in nm

SAMPLE MISSION PLANNING LOG

III LO HI INTERDICTION

PHASE OF MISSION	POWER SETTING	* FUEL USED - LB	TIME	DISTANCE	POSITION	TOTAL GROSS WEIGHT - LB	TOTAL TIME	TOTAL DISTANCE	AIR SPEED	ALTITUDE - FT
SAMPLE TAKE OFF	100% AME	524	1.1	3	START	20,502	0	0	---	50
CLIMB TO 30,000 FT	80%	1120	15	105	END	19,382	1	0	30,000	30,000
CRUISE AT 30,000 FT	0.85 (107%)	1365	24.6	205	START	18,017	22.1	105	30,000	30,000
CLIMB AT SEA LEVEL	AME	790	5	0	START	17,227	40.7	105	---	50
CRUISE AT SEA LEVEL	0.85 (107%)	1000	28.6	241	END	16,227	41	105	---	50
CLIMB TO 30,000 FT	AME	725	12.8	27	START	15,502	51.7	105	---	50
CRUISE AT LONG RANGE SPEED AT 30,000 FT	0.88 (109%)	1000	28.6	241	END	14,502	80.3	0	---	30,000
LANDING FUEL RESERVES	---	600	0	0	START	13,902	80.3	0	---	50
					END	13,302	80.3	0	---	50

* USABLE FUEL WEIGHT
 INTERDICT 4400 LB
 CRUISE FUEL 1725 LB
 TOTAL 6125 LB

[] STORE WEIGHT ONLY

DATA BASIS

- STANDARD DATA
- ZERO WIND CORRECTIONS
- FUEL CONSUMPTION BASED ON 100% EFFICIENCY

1-5-1-7-1100

FA10-1.

A10-5

The equation to balance the mission is now written and solved as follows:

Total Distance Outbound Inbound Outbound Cruise Leg = 108 nm Cruise Leg = 72 nm $0.15X + 108$ $0.15X + 108$ $0.15X + 0.240X$ $0.390X$ X $2366 - X$ 0.15×1364 0.24×1002 To check the results of equation $205 + 108$ 313 nm	Total Distance Inbound Inbound $0.24(2366 - X) + 72$ $(568 - 0.240X) + 72$ $(568 + 72) - 108$ 532 1364 lb of fuel for outbound cruise leg 1002 lb of fuel for inbound cruise leg 205 nm outbound cruise leg = 241 nm inbound cruise leg $241 + 72$ 313 nm
--	---

GRAPHIC SOLUTION OF MISSION

Figure I A10-2 graphically illustrates the sample mission illustrated in I A10-1 and can be used to study the effects of various modifications on the radius of any similar mission. The solid lines are a plot of fuel remaining versus mission radius in the sample mission. If the slopes of the return climb and cruise lines are maintained, these lines may be shifted with changes in combat fuel or landing fuel and the resulting mission radius determined with reasonable accuracy. The dashed lines show the effects of changes in the mission.

TAKEOFF AND LANDING DATA CARD

The following example illustrates the preparation of the takeoff and landing data card. Takeoff and landing data are obtained from parts 2 and 7, respectively and the fuel allowance for taxi is obtained from the fuel flow rates tabulated on I A1-1. The takeoff weight is the gross weight with full fuel less the fuel allowance for taxi and engine rump at military power. The landing weight immediately after takeoff with two engines operating and with stores, and for single engine after stores are jettisoned is the takeoff weight less an average fuel allowance of 300 lb for takeoff and go-around.

For the purpose of the sample problem, the conditions and calculations are as follows:

Gross Weight (Full Fuel)	20,582 lb and cg
	13% MAC
Gross Weight (Payload Stores Jettisoned)	16,454 lb and cg
	11% MAC
Runway Pressure Altitude	Sea Level
Runway Temperature	10°C
Wmd	10 kt from 60
Runway Length	11,000 ft
Runway Slope	1% up/dn
RCR (Wet Runway)	12
Drag Chute Option	No chute
Flap Position	FLU1

The takeoff calculations are as follows:

Taxi Fuel Allowance	48 lb/nm x 5
	900 lb fuel
Engine Rump at MH	119 lb/nm x 1
	119 lb fuel
Takeoff Gross Weight (With Stores)	20,582 - (900 + 119)
	19,563 lb
Headwind Component (I A1-9)	5 kt
Takeoff Speed (I A2-2)	177 KIAS
Alt Stick Speed (I A2-2)	167 KIAS
Takeoff Factor (I A2-4)	12.4

HI-LO-HI INTERDICTION PROFILE



- (4) MK-82 LD
- (2) AIM-9J MISSILES
- (1) CL 275-GAL TANK

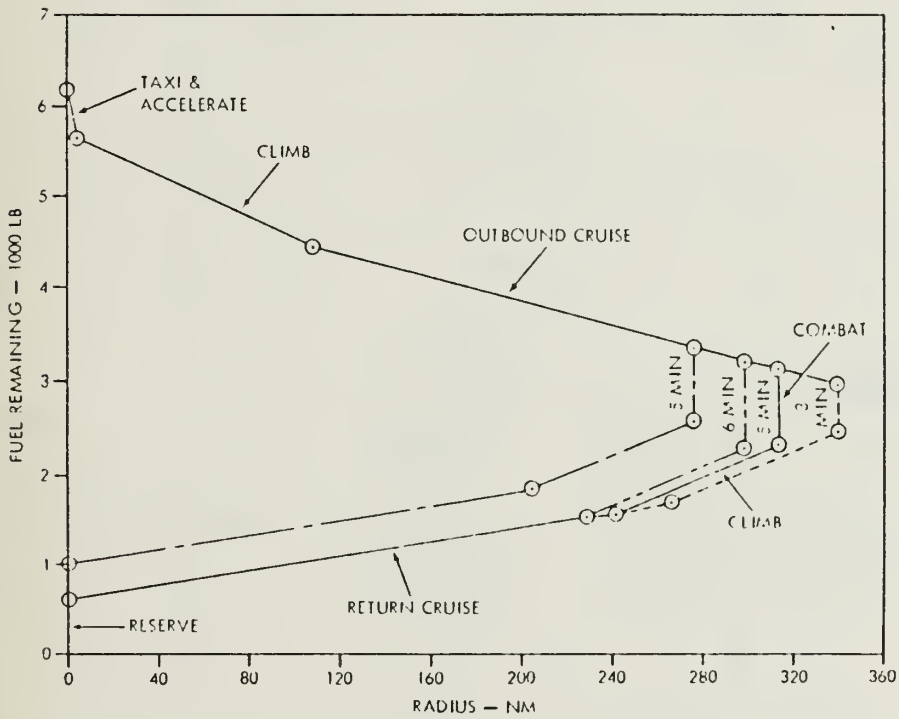

F-5 1-627(1)B

FA10-2.

A10-7

Appendix I
Part 10. Mission Planning

T.O. 1F-5E-1

Lakeoff Ground Run (5 kt Headwind, 1% uphill (FA7-5)	3200 ± 160 3360 ft
Lakeoff Gross Weight (Payload Stores Jettisoned)	16,454 ± 190 (± 119) 16,245 lb
Minimum Safe Single- Engine Lakeoff Speed (Stores Jettisoned) (FA2-7)	154 KIAS
(With Stores) (FA2-7)	206 KIAS
Critical Field Length (with stores), No Drag Chute, 5 kt Headwind, RCR = 23, 1% uphill (FA2-10)	7800 ± 390 8190 ft
RCR = 12, 1% uphill (FA2-10)	8700 ± 435 9135 ft
Critical Engine Failure Speed, No Drag Chute, 5 kt Headwind, RCR = 12, (FA2-12)	141 ± 5 ± 146 KIAS
Retrial Speed, No Drag Chute, 5 kt Headwind, RCR = 12, (FA2-12)	160 ± 5 ± 165 KIAS
Decision Speed, 5 kt Headwind (FA2-15)	135 KIAS
Normal Acceleration Speed at 2000 ft (FA2-16)	140 KIAS
Acceleration Tolerance: 11,000 8190 1000 x 3 = 8 KIAS	
Check speed at 2000 ft marker	110 ± 8 = 132 KIAS

The landing conditions are as follows:

	Altitude Lakeoff and Go Around	Altitude Top Payload Stores	Final Landing
Edg Gr Wt	20,073 lb	15,915 lb	12,000 lb
C/G (% MAC)	13	14	18
Press Alt	SI	SI	SI
Temperature	+10	+10	+10
Headwind	5 kt	5 kt	20 kt
Rwy Length	11,000 ft	11,000 ft	11,000 ft
RCR	12	12	12
Drag Chute	No Chute	No Chute	No Chute
Flaps	1ULL	1ULL	1ULL

The landing calculations are as follows:

Approach Speed (FA7-1, sheet 1)	193 KIAS	171 KIAS	146 KIAS
Touchdown (FA7-1, sheet 1)	190 KIAS	160 KIAS	137 KIAS
Landing Ground Roll, No Drag Chute			
FA7-2	5400 ft	4200 ft	2600 ft
RCR of 12/12/12			
FA7-4	8100 ft	6600 ft	4100 ft
Landing Ground Roll With Drag Chute			
FA7-3	3600 ft	3000 ft	1900 ft
RCR of 12/12/12			
FA7-5	4700 ft	3900 ft	2450 ft
Minimum Distance from Touchdown to 125 Kt Hook Engagement:			
No Drag Chute RCR of 12/12/12			
FA7-7	3700 ft	2700 ft	650 ft

TAKEOFF AND LANDING DATA CARD**CONDITIONS**

	TAKEOFF	LANDING
GROSS WEIGHT & CG	20,373 LB 13%	12,000 LB 13%
RUNWAY LENGTH	11,000 FT	11,000 FT
RUNWAY PRESSURE ALTITUDE	51	51
RUNWAY SLOPE	UPHILL 1%	_____ %
RUNWAY TEMPERATURE	41°C	41°C
RUNWAY WIND COMPONENT	HEADWIND 5 KT	HEADWIND 20 KT
DRAG CHUTE OPTION	NO CHUTE	CHUTE OR NO CHUTE
RCR	12	12

TAKEOFF

ACCELERATION CHECK SPEED & MARKER	132 KIAS	2000 FT
CRITICAL ENGINE FAILURE SPEED	146 KIAS	
DECISION SPEED	135 KIAS	
AFT STICK SPEED	167 KIAS	
TAKE OFF SPEED & GROUND RUN DISTANCE	177 KIAS	4260 FT
MINIMUM SAFE SINGLE-ENGINE SPEED:		
WITH STORES	206 KIAS	
NO STORES (OR JETTISONED)	154 KIAS	

LANDING

	AFTER TAKEOFF & GO-AROUND		FINAL LANDING
	TWO ENGINES (W/STORES)	SINGLE ENGINE (W/O STORES)	
GROSS WEIGHT & CG	20,373 LB 13%	15,945 LB 14%	12,000 LB 13%
FINAL APPROACH SPEED	193 KIAS	173 KIAS	134 KIAS
TOUCHDOWN SPEED	170 KIAS	160 KIAS	127 KIAS
MAX HOOK ENGAGEMENT SPEED	125 KT	125 KT	125 KT
LANDING GROUND ROLL:			
WITH DRAG CHUTE	4700 FT	3700 FT	2450 FT
NO DRAG CHUTE	8100 FT	6600 FT	4100 FT
DISTANCE FROM TOUCHDOWN TO HOOK ENGAGEMENT	3700 FT	2200 FT	650 FT

1-5 1-672111

FA 10-3.

Change 4

A10-9/(A10-10 blank)

LIST OF REFERENCES

1. Jane's All the World's Aircraft, 1945-46.
2. Casey L. S. and Batchelor J., "The Illustrated History of Seaplanes and Flying Boats", Exeter Books, 1980.
3. Shin Meiwa Industry Co., Ltd. - US - 1A STOL Amphibious Aircraft, Aircraft Division, Head Office 5-25, Kosone-cho 1-chome, Nishinomiya-shi, Hyogo-ken, Japan.
4. Aviones de Guerra, Editora Abril, SP Brasil, 1986-7
5. Aviation Week & Space Technology, "U.S. Demonstrates Advanced Weapons Technology in Libya", pp. 18-21, April 21, 1986.
6. T. O. 1F - 5E - 3, USAF Series F-5E and F-5F Structural Repair - Change 2 - 1 May 75
7. JANE's - All The World's Aircraft, 1980-81
8. T. O. 1F - 5E - 3, USAF Series F-5E/F Flight Manual - Change 6 - 1 August 1986.
9. Wood, R. D., "Aerospace Vehicle Design", Volume I, Aircraft Design - Second Edition, Johnson Publishing Company, Boulder, Colorado, 1968.
10. Aviation Week and Space Technology, May 16, 1977, "Japanese Pushing Flying Boat Designs", pp. 45-47.
11. Kohlman, D. L., "Introduction to V/STOL Airplanes", Iowa State University Press / AMES, 1981.
12. Taylor, J. W. R. and K. Murson, "History of Aviation", Crown Publishers 1976.
13. Aviation Week & Space Technology, "U.S. Demonstrates Advanced Weapons Technology in Libya", pp.18-21, April 21, 1986.
14. Nelson, W., "Seaplane Design", McGraw-Hill Book Company, Inc., 1934.
15. King, H. F., "Aeromarine Origins", Aero Publishers Inc., 1966.
16. Gunston, B., "An Illustrated Guide to Modern Airborne Missiles", Aero Publishing, Inc., 1983
17. Gunston, B., "An Illustrated Guide to Modern Fighters and Attack Aircraft", Arco Publishing Inc., 1980.
18. Artigiani, Robert., "Seaplanes: Past Problems and Future Prospects", A Report to the Advanced Concepts Division of the Naval Air Systems Command, 1980.

19. Kapryan, W. J., Goodson, K. W., Weinstein, I., "Aerodynamic and Hydrodynamic Characteristics of a Model of a 500,000 lb High-Subsonic Multijet Logistics Transport Seaplane", NASA 1961.
20. Locke, F. W. S. Jr., "The Attack Seaplane Task Force vs. The Attack Carrier Task Force", Bureau of Aeronautics 1954.
21. Lockheed Aircraft Corporation, "Naval Airborne Attack Systems for the 1965 Period", Office of Naval Research 1956.
22. Platzer, M. F., "The Future of Naval Aviation - A Third Approach", Naval War College Review, November-December 1982.

INITIAL DISTRIBUTION LIST

	No. Copies
1. Defense Technical Information Center Cameron Station Alexandria, VA 22304-6145	2
2. Library, Code 0142 Naval Postgraduate School Monterey, CA 93943-5002	2
3. Professor Max F. Platzer Department of Aeronautics Naval Postgraduate School Monterey, CA 93943-5000	2
4. Professor Richard William Bell Department of Aeronautics Naval Postgraduate School Monterey, CA 93943-5000	1
5. Professor Robert E. Ball Department of Aeronautics Naval Postgraduate School Monterey, CA 93943-5000	1
6. Professor Richard D. Wood 465, San Antonio Way Palo Alto, CA 94306	1
7. Professor Donald M. Layton 44, Seca Place Salinas, CA 93908	1
8. Adjunct Professor Wayne P. Hughes, Jr. Department of Operations Research, Code 55Hi Naval Postgraduate School Monterey, CA 93943	1
9. Lt. Col. Algeu Kreniski Centro Tecnico Aeroespacial-IAE-ESB 12 225 - Sao Jose dos Campos - SP, Brasil	1
10. Director do Centro Tecnico Aeroespacial Centro Tecnico Aeroespacial 12 225 - Sao Jose dos Campos - SP, Brasil	1
11. Director do Instituto de Atividades Espaciais Centro Tecnico Aeroespacial - IAE 12 225 - Sao Jose dos Campos - SP, Brasil	1

12. Chefe da Divisao de Sistemas Belicos 1
Centro Tecnico Aeroespacial
12 225 - Sao Jose dos Campos - SP, Brasil
13. Biblioteca do ITA 1
Centro Tecnico Aeroespacial
12 225 - Sao Jose dos Campos - SP, Brasil
14. Director da EMBRAER 1
Empresa Brasileira de Aeronautica
Sao Jose dos Campos - SP, Brasil
15. Reitor da Fundacao Tecnico Educacional Souza Marques 1
Av. Ernani Cardoso, S/N - Campinho
Rio de Janeiro - Brasil

Thesis
K8624 Kreniski
c.1 The use of seaplanes as
an advanced weapon sys-
tem.

Thesis
K8624 Kreniski
c.1 The use of seaplanes as
an advanced weapon sys-
tem.



thesK8624

The use of seaplanes as an advanced weap



3 2768 000 84642 2
DUDLEY KNOX LIBRARY